

V4 January 2021

## Classic Technical Cad Specs

## Low Pitch Eaves Beam

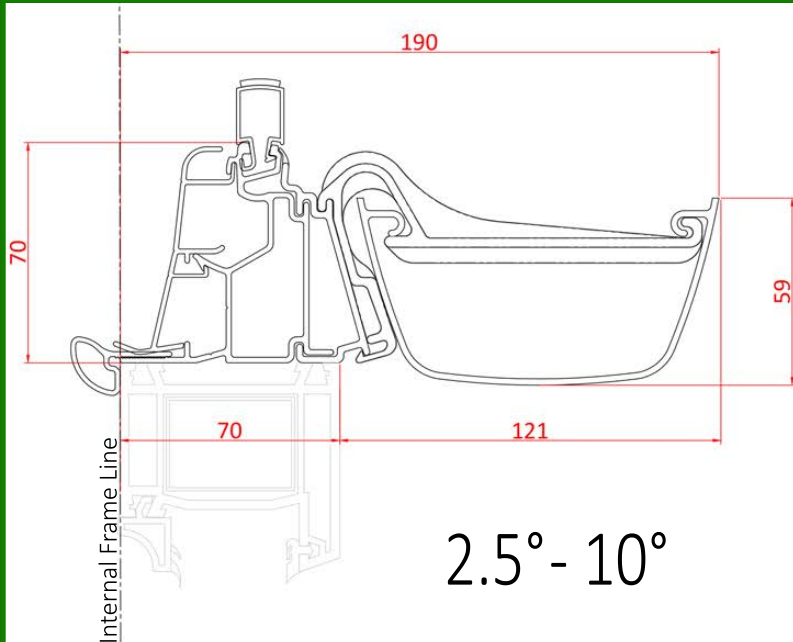

2.5° - 10°

## Gable Beam Support

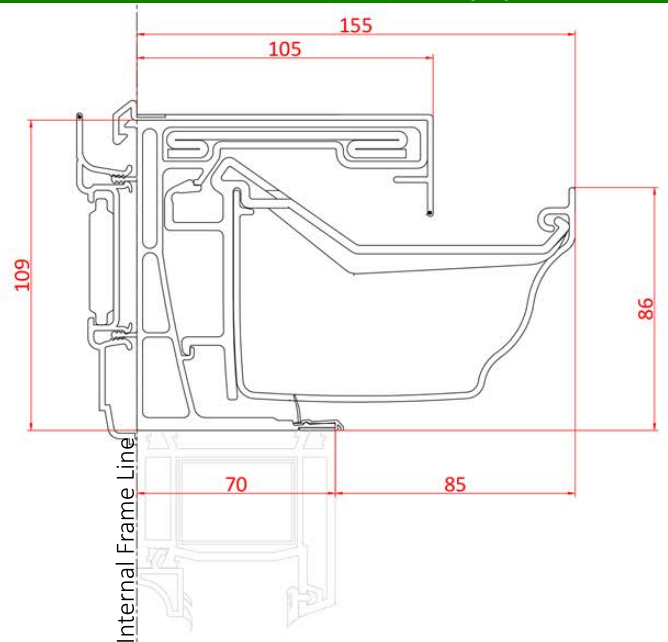

## Rider Rail Eaves

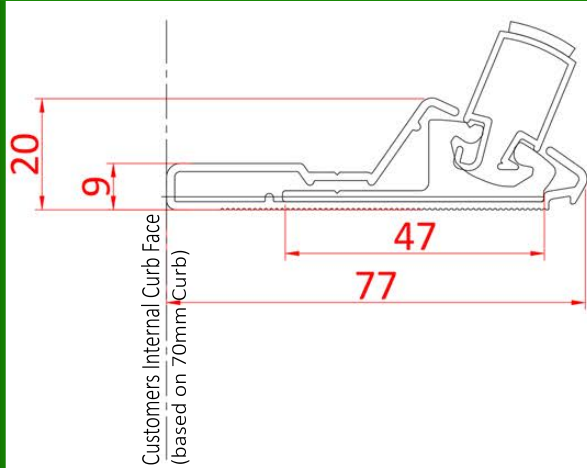

## Lantern Eaves (25°)

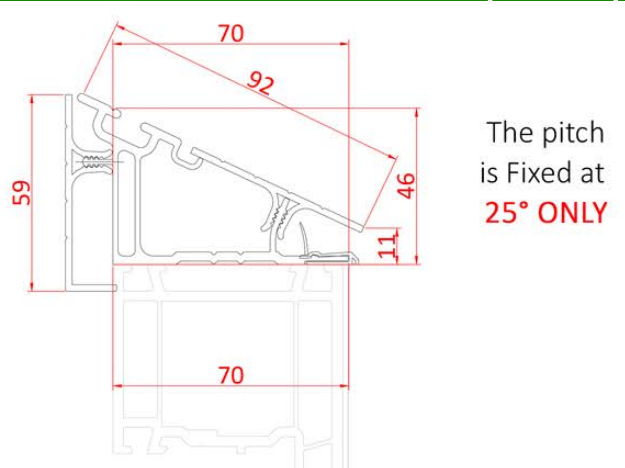

## Standard Eaves Beam

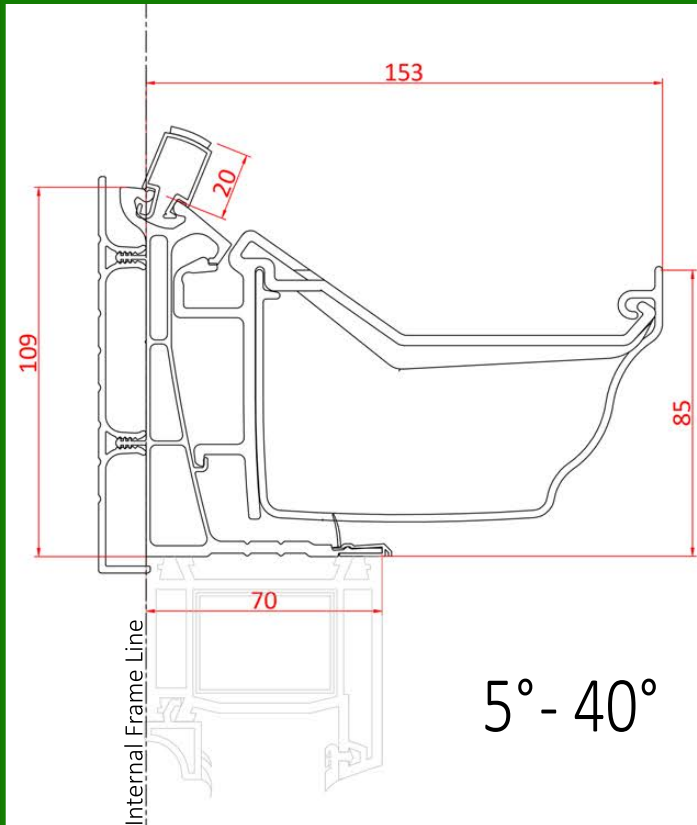

5° - 40°

## Structural Eaves Beam

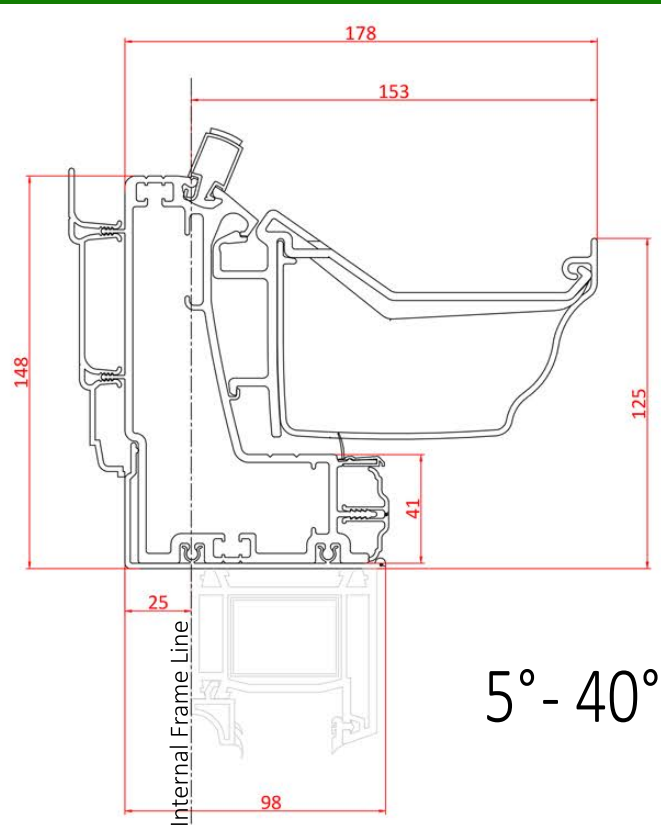

5° - 40°

# Eaves and Glazing Bar Heights

## Standard Eaves At 5° Increments

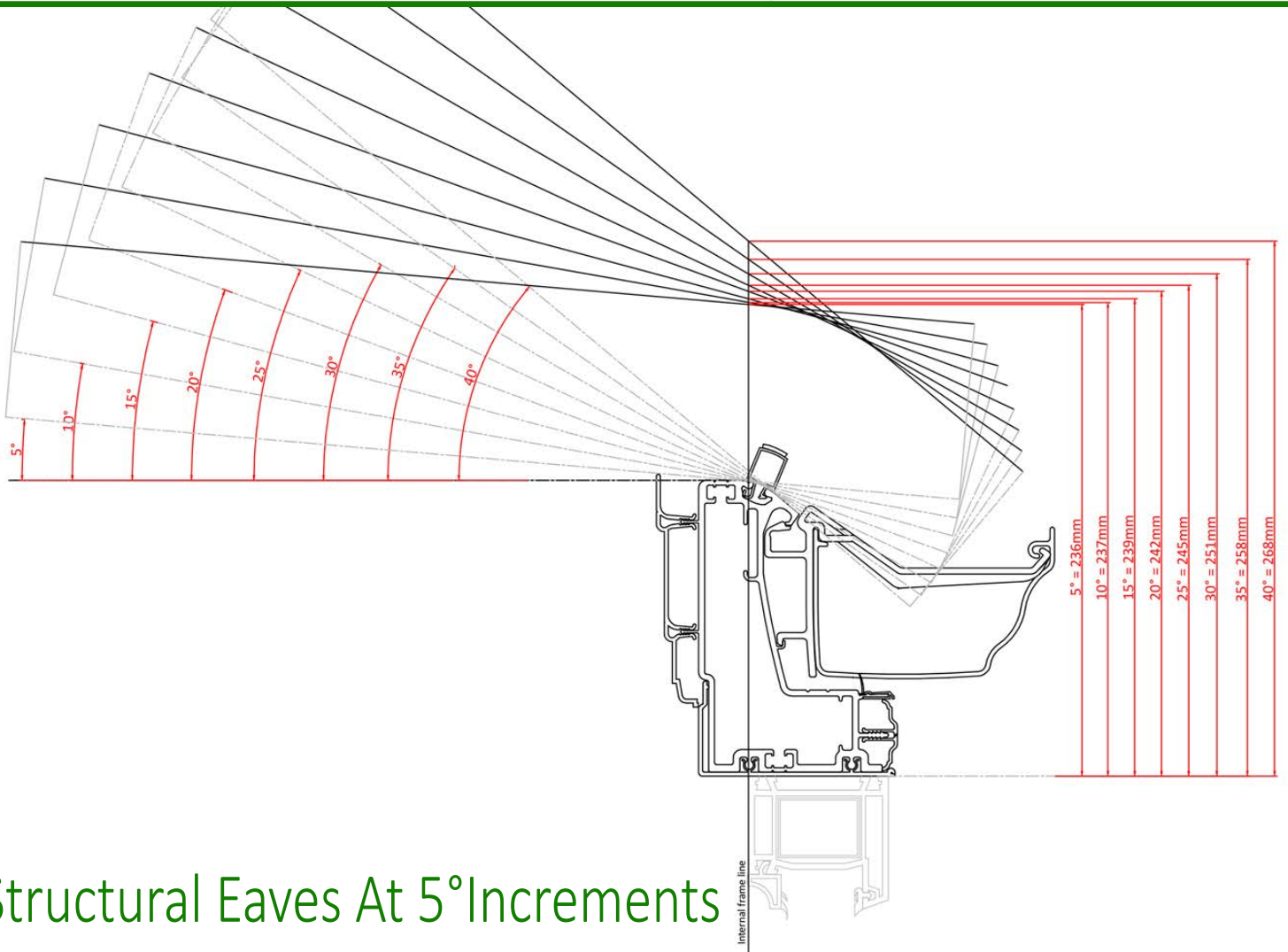
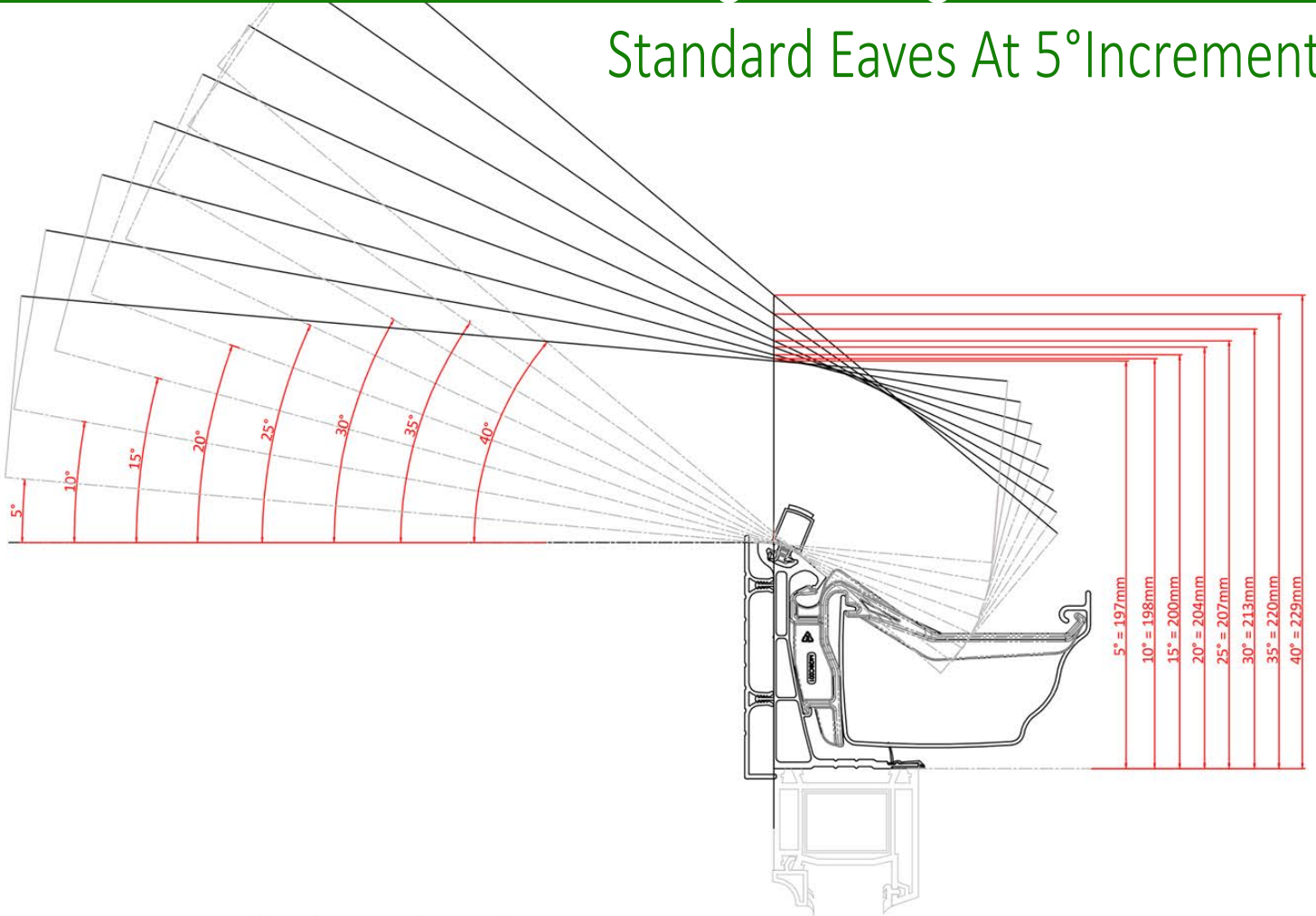

## Structural Eaves At 5° Increments

# Low Pitch Eaves Beam With Glazing Bar Heights

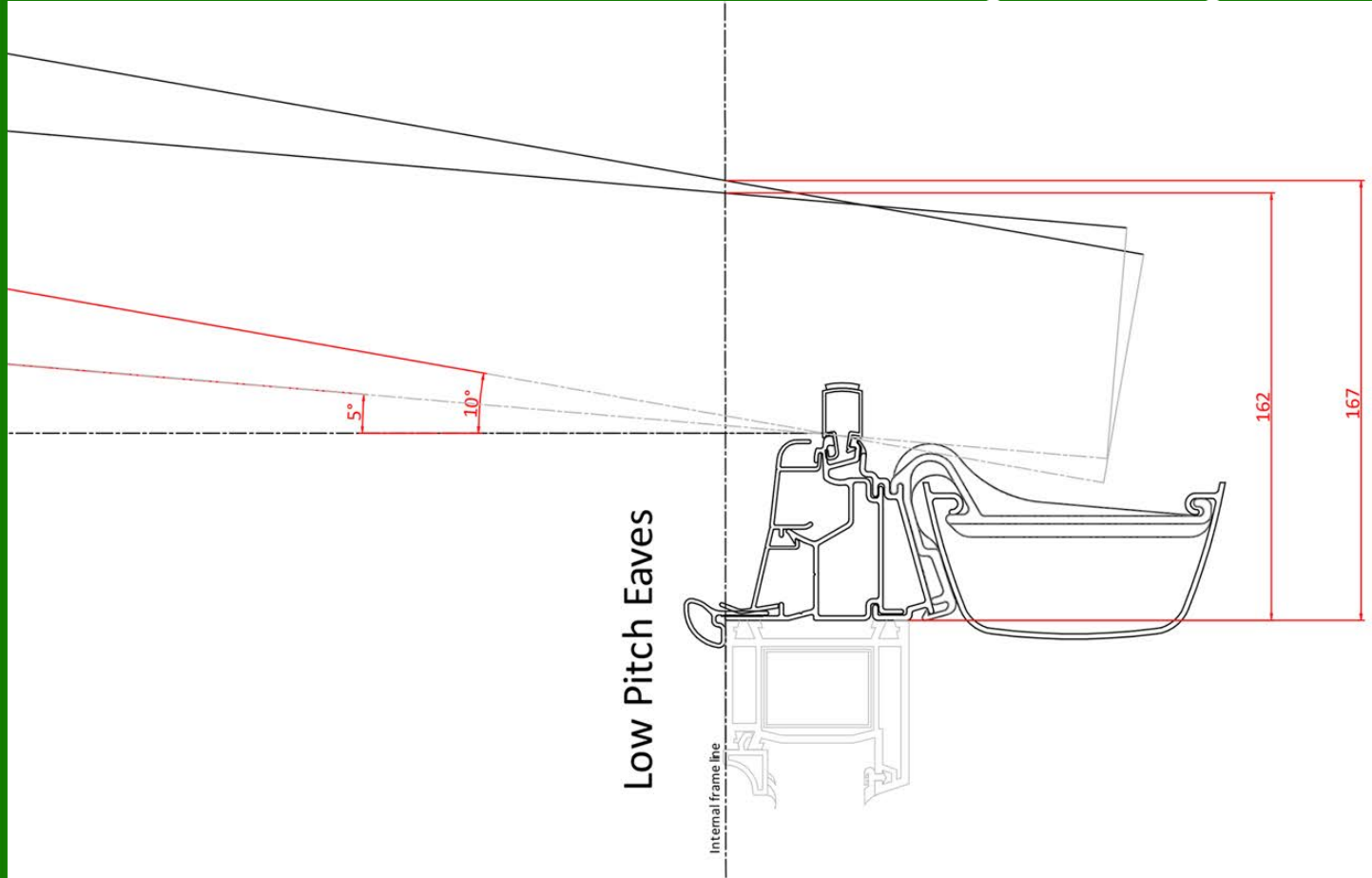

SIMPLIFIED FORMULA FOR CALCULATING HEIGHT FROM UNDERSIDE OF EAVES TO TOP OF RAKED FRAME @ WALL

$$(PROJECTION + 43) * \tan(PITCH) + 70$$

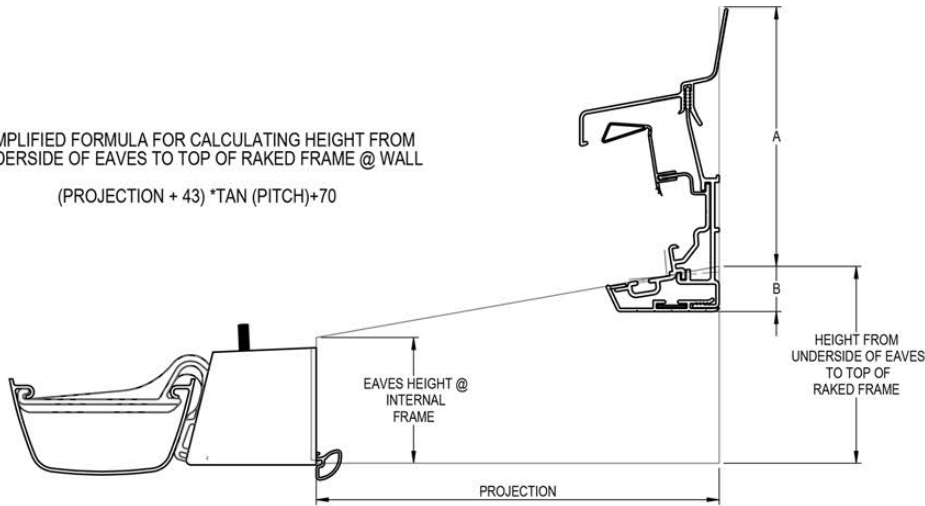

	DIM A	DIM B	
PITCH IN DEGREES	2.5	166	23
	3	165	24
	3.5	165	24
	4	165	24
	4.5	165	24
	5	164	25
	5.5	164	25
	6	164	25
	6.5	163	26
	7	163	26
7.5	163	26	
8	163	26	
8.5	162	27	
9	162	27	
9.5	162	27	
10	161	28	

HEIGHT FROM UNDERSIDE OF EAVES TO TOP OF RAKED FRAME AT WALL

PITCH IN DEGREES	EAVES HEIGHT @ INTERNAL FRAME	PROJECTION (mm)															
		2500	2600	2700	2800	2900	3000	3100	3200	3300	3400	3500	3600	3700	3800	3900	4000
2.5	72	181	185	190	194	198	203	207	212	216	220	225	229	233	238	242	247
3	72	203	209	214	219	224	229	235	240	245	250	256	261	266	271	277	282
3.5	73	226	232	238	244	250	256	262	268	274	281	287	293	299	305	311	317
4	73	248	255	262	269	276	283	290	297	304	311	318	325	332	339	346	353
4.5	74	270	278	286	294	302	309	317	325	333	341	349	357	365	372	380	388
5	74	292	301	310	319	327	336	345	354	362	371	380	389	397	406	415	424
5.5	74	315	324	334	344	353	363	373	382	392	402	411	421	430	440	450	459
6	75	337	348	358	369	379	390	400	411	421	432	442	453	463	474	484	495
6.5	75	360	371	383	394	405	417	428	439	451	462	474	485	496	508	519	531
7	76	382	395	407	419	431	444	456	468	480	493	505	517	530	542	554	566
7.5	76	405	418	431	444	457	471	484	497	510	523	536	550	563	576	589	602
8	76	427	441	456	470	484	498	512	526	540	554	568	582	596	610	624	638
8.5	77	450	465	480	495	510	525	540	555	570	585	600	614	629	644	659	674
9	77	473	489	504	520	536	552	568	584	599	615	631	647	663	679	695	710
9.5	78	496	512	529	546	562	579	596	613	629	646	663	680	696	713	730	747
10	78	518	536	554	571	589	607	624	642	659	677	695	712	730	748	765	783

# New Bifold Door Support Bolsters

Bi Fold Support Eaves

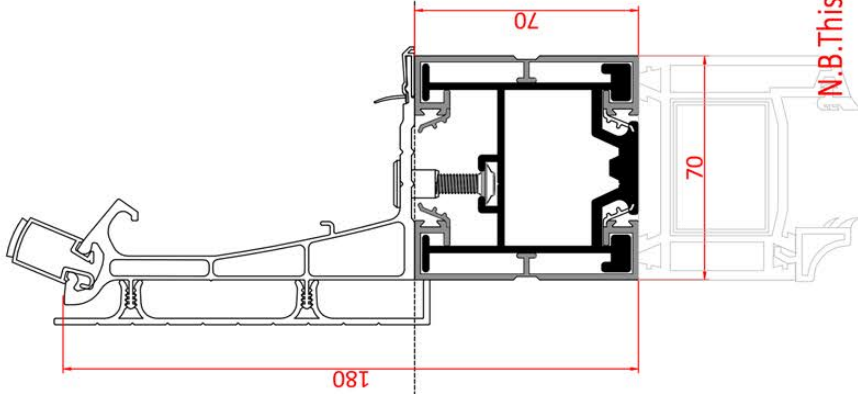

Super Bolster Eaves

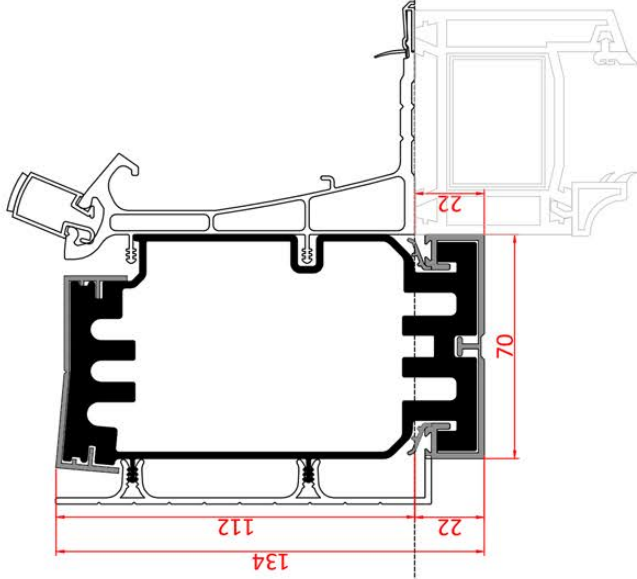

Combination Eaves

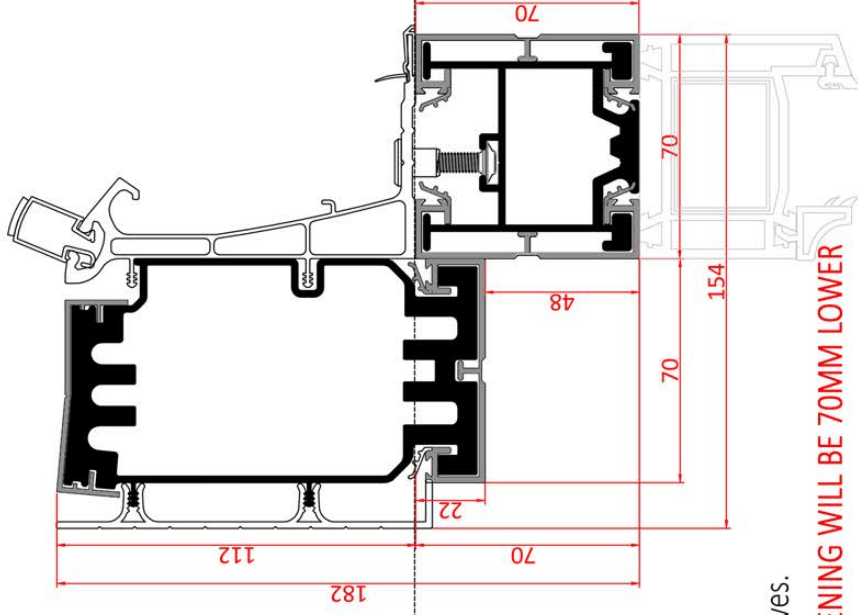

Bi Fold Support Beam which mounts to the underside of the eaves.

**N.B. This means either THE ROOF WILL BE 70MM HIGHER OVERALL OR THE DOOR OPENING WILL BE 70MM LOWER**

**Bolster which mounts to the inside of the eaves beam. N.B. THE BOLSTER SIT 22MM LOWER THE THE EAVES BEAM AND MAY INTERFERE WITH THE DOORS!**

The 2 profiles can be used separately to bolster the eaves or combined to further increase the spanning capability.

The bolster sections only need to be specified on the elevation where the larger opening is required (**SEE GUIDE CHART ON NEXT PAGE**).

The bi fold support beam is 70mm tall and runs between corner posts.

**On the elevations which do not require the spanning capability, either the frame height can be adjusted, or a standard frame add on or corner post profile can be used to pack the frames under the eaves.**

# New Bifold Door Support Bolster Span Chart

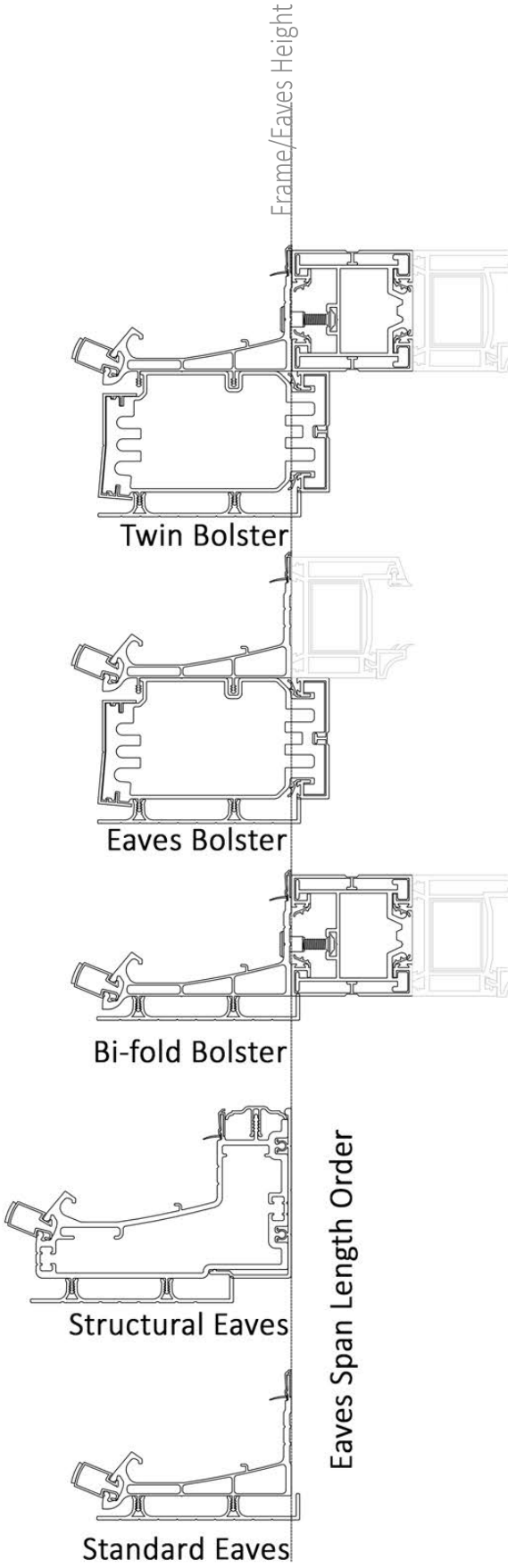

Eaves Span Length Order

## Eaves Span Chart - Standard Load - Glass (4/.. /4) - Snow 0.6kN/m<sup>2</sup>

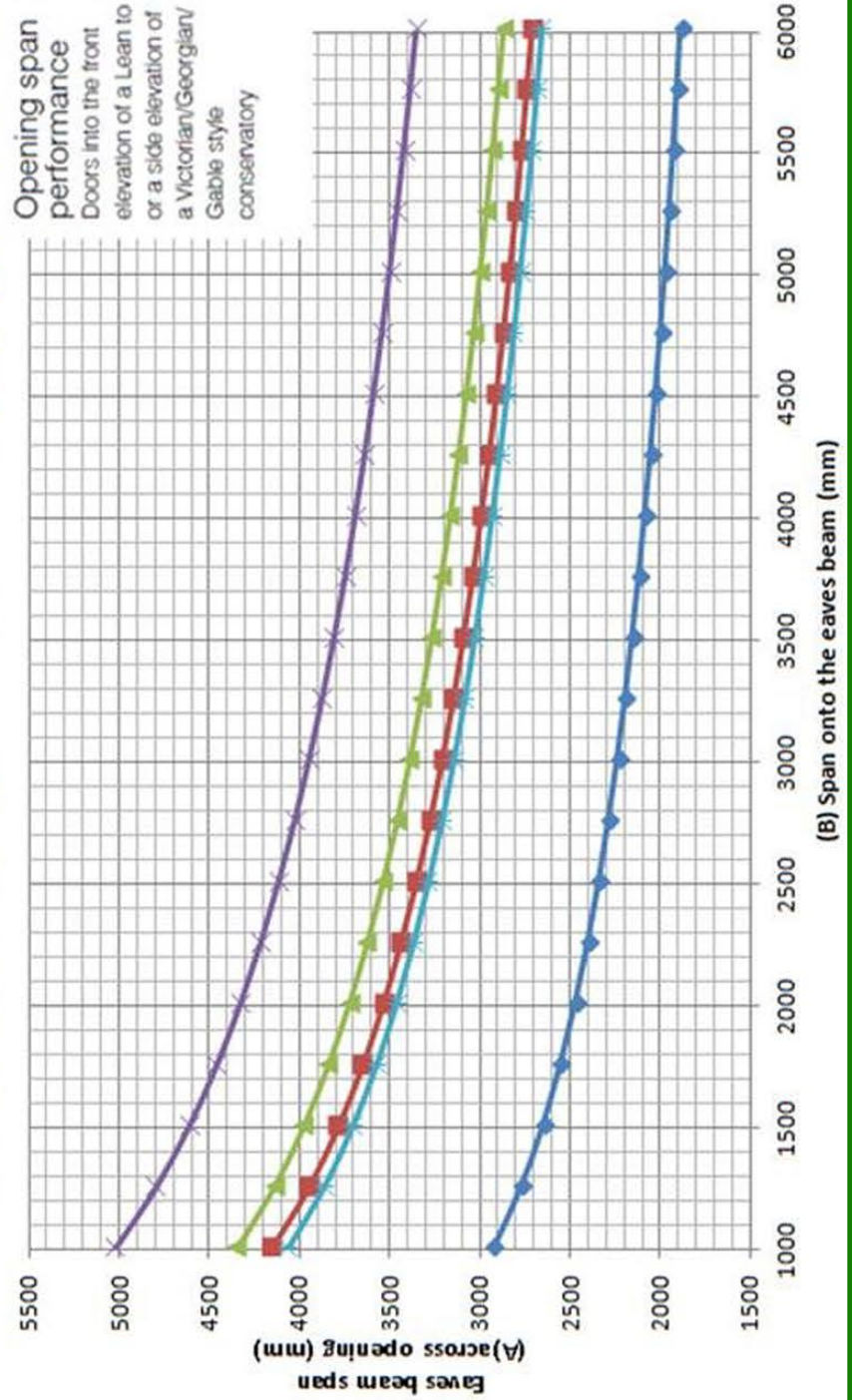

# 165m Boxgutter

## 165mm Boxgutter with strap

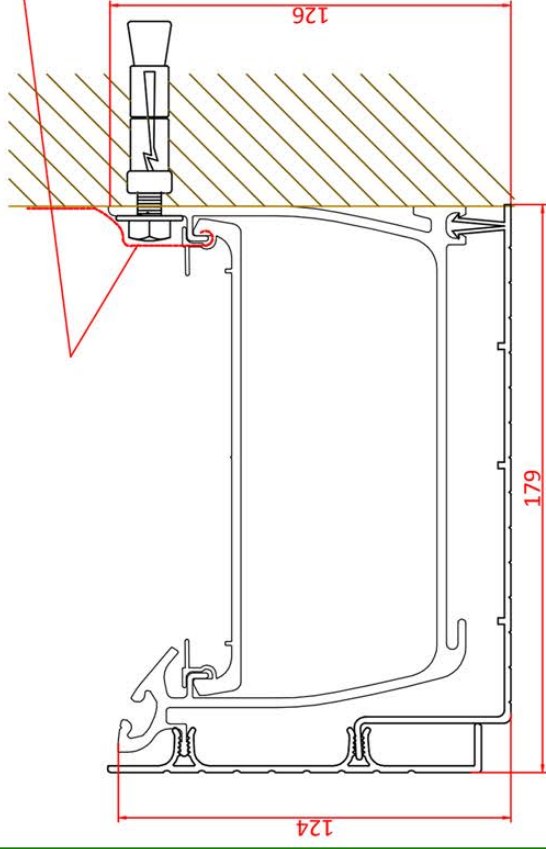

## 265mm Boxgutter with strap

Leading area (by others).  
The leading shown is for lead location purposes only and the actual leading and position is the sole responsibility of the installer

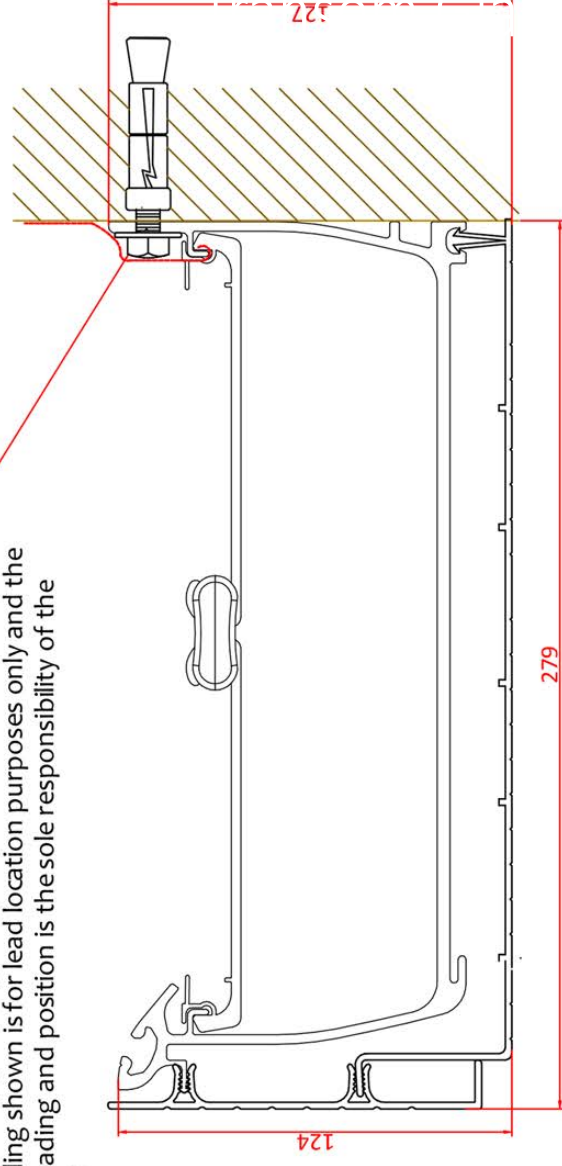

## 165mm Boxgutter without strap

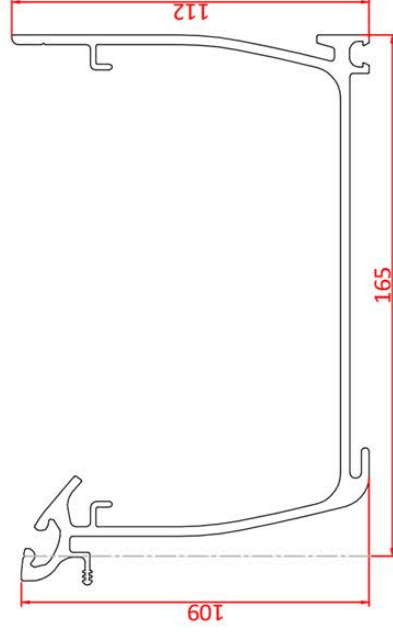

## 265mm Boxgutter without strap







# 165m Chambered Boxgutter (packers required)

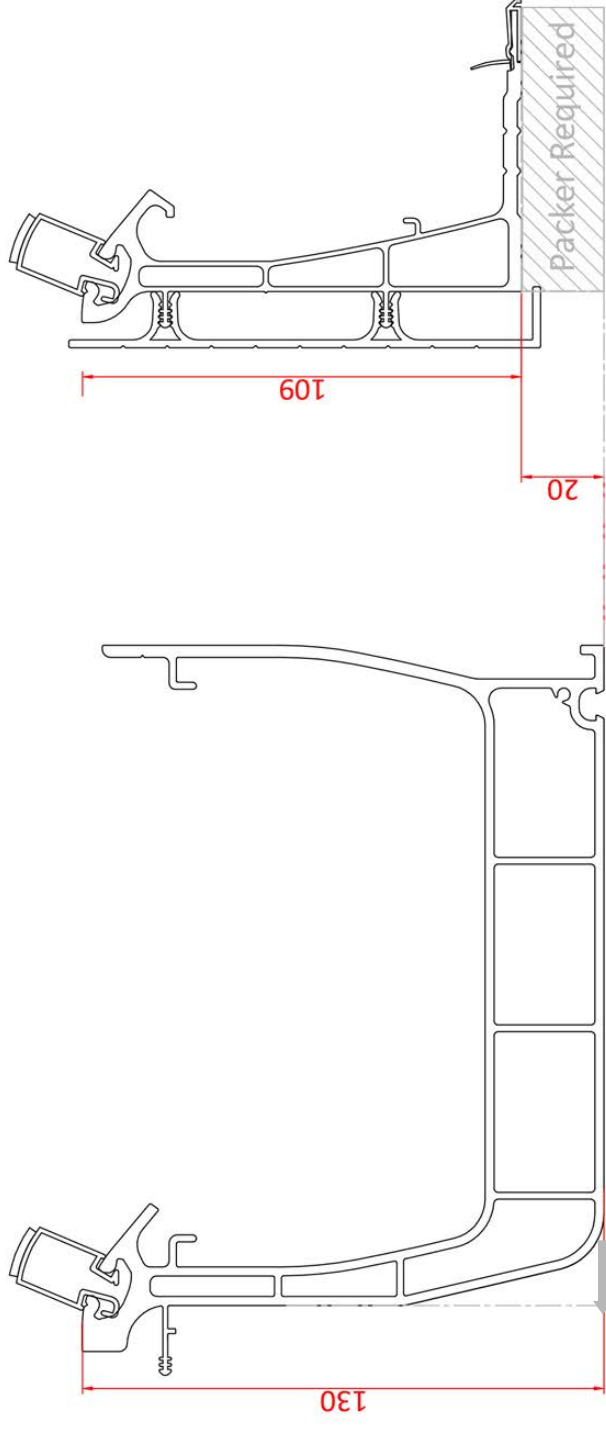
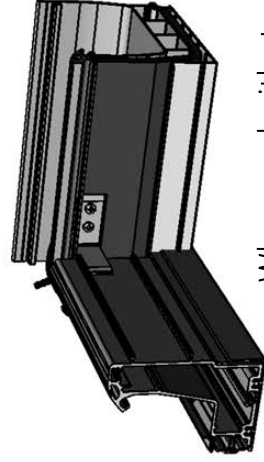
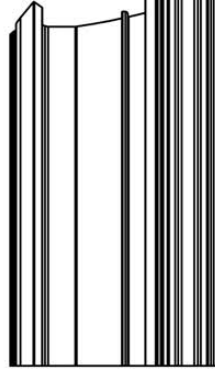
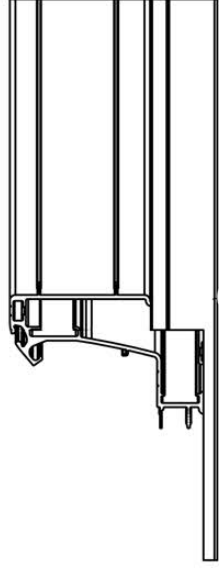

- Chambered section enables spanning capability up to 4 meters without the requirement for gallow brackets.
- Compatible with both Standard Eaves beam and Super Duty Eaves.
- When used with standard Eaves above, a 20mm window frame add on is required to pack the eaves and ensure that the parabolic head aligns.
- A blanking plate endcap is specified with Standard eaves to close off the chambered end of the boxgutter.
- The DFS on the front of the super duty eaves beam is used to close off the chambered end of the boxgutter instead of blanking plate
- Chambered boxgutter is compatible with all current 165mm adaptors



# Box Gutter Support

## GALLOWS / HANGING BRACKETS MEASUREMENTS

### 165 Gallows Bracket

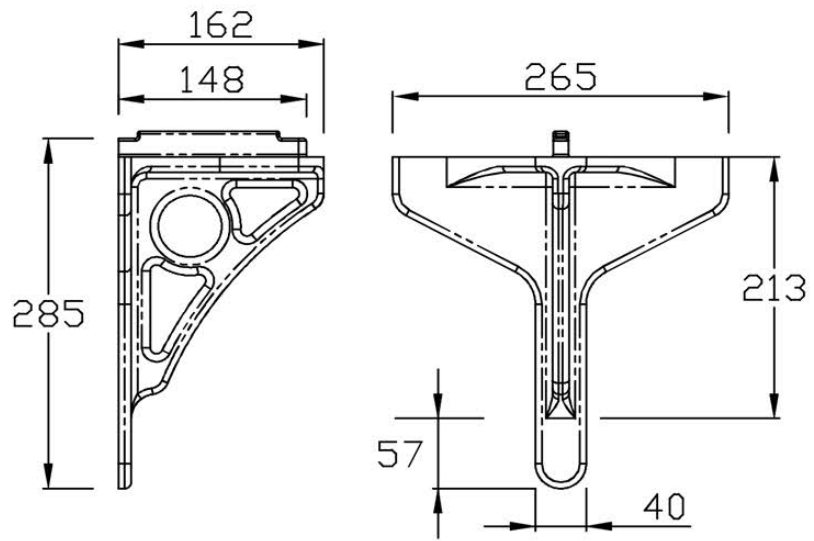

### 265 Gallows Bracket

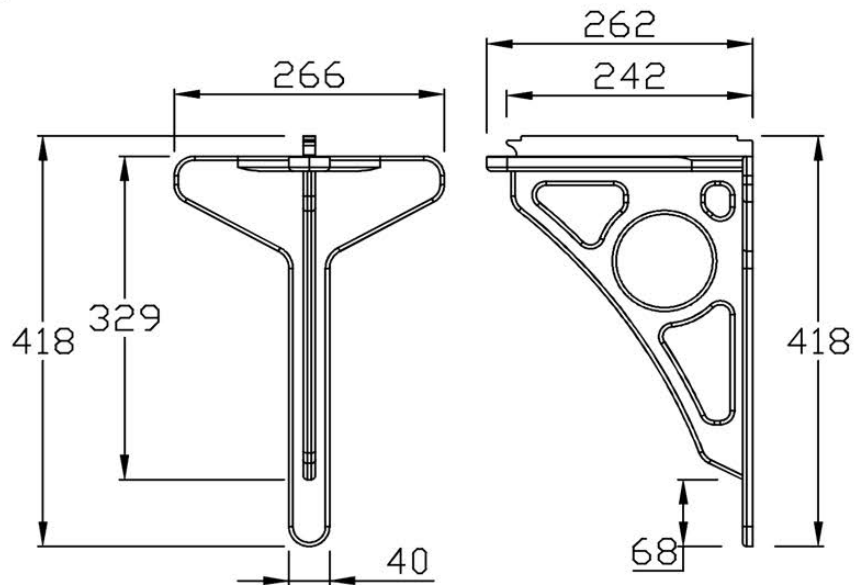

### 165 Hanging Bracket

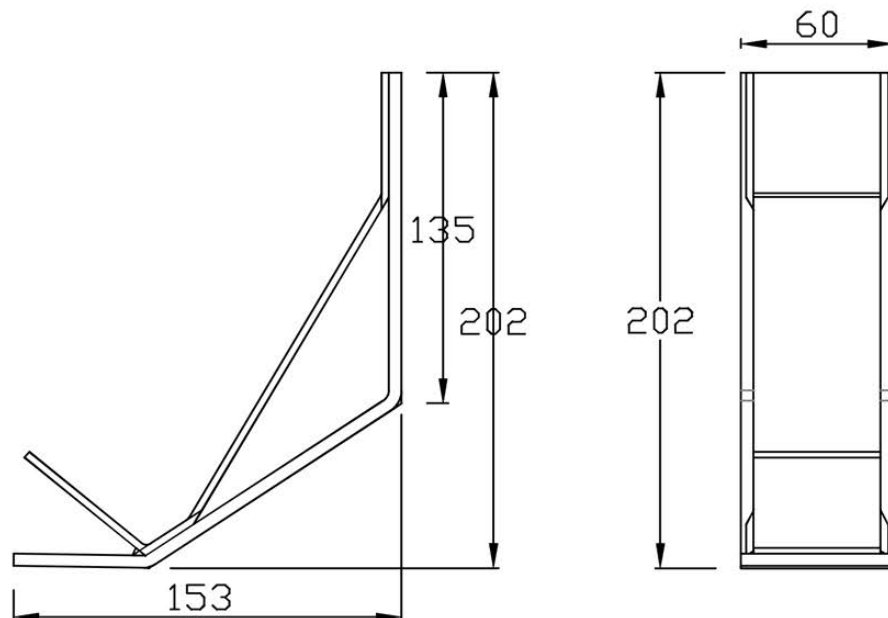

# MK 5 Half Ridge 5°-40°

# Ventilated Wallplate 5°-40°

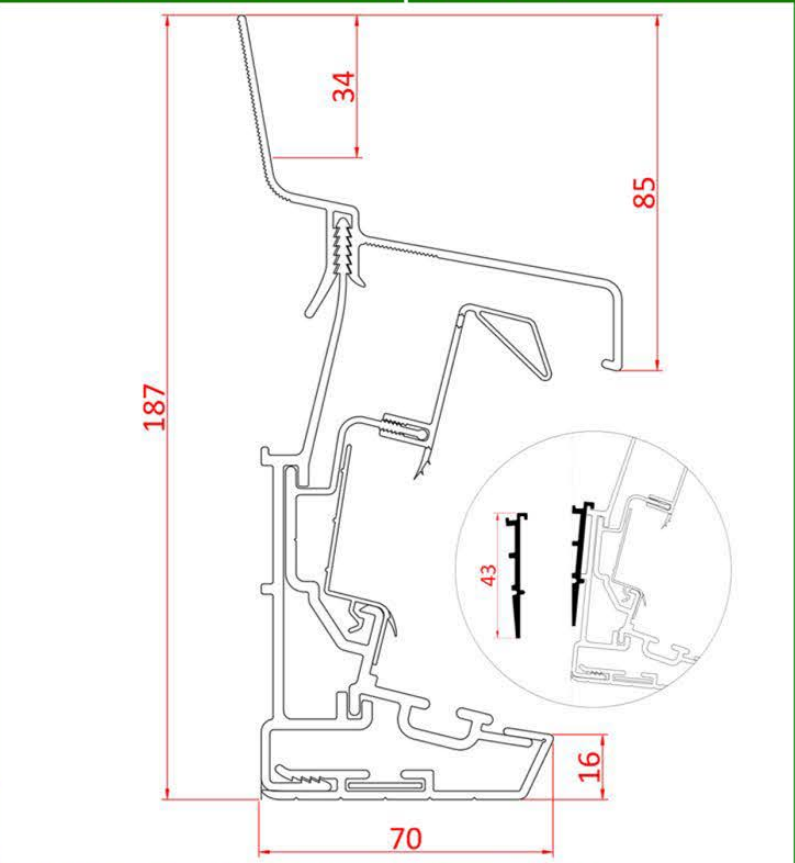
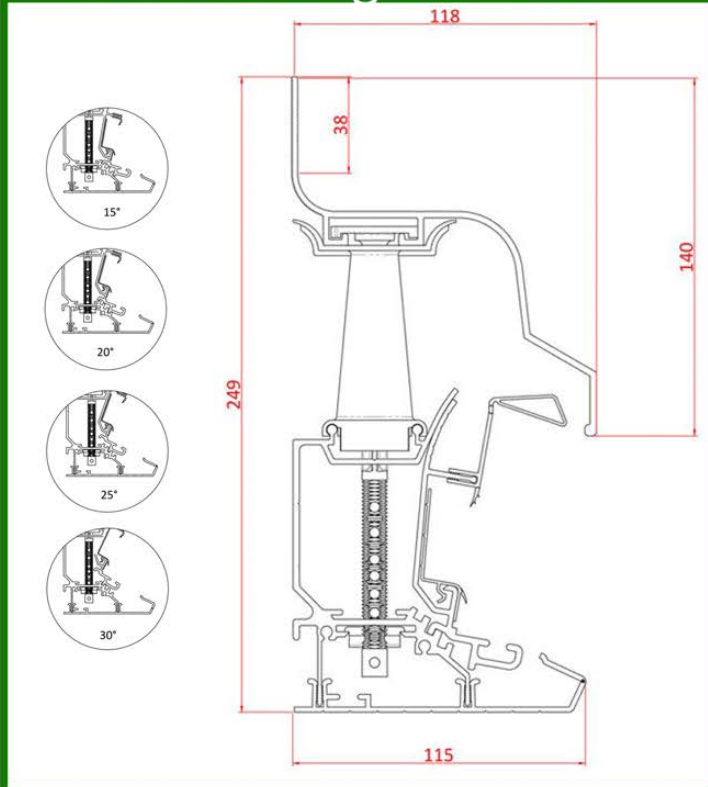

# Ultrasky Ridge (Fixed 25°)

# MK 5 Full Ridge 5° - 40°

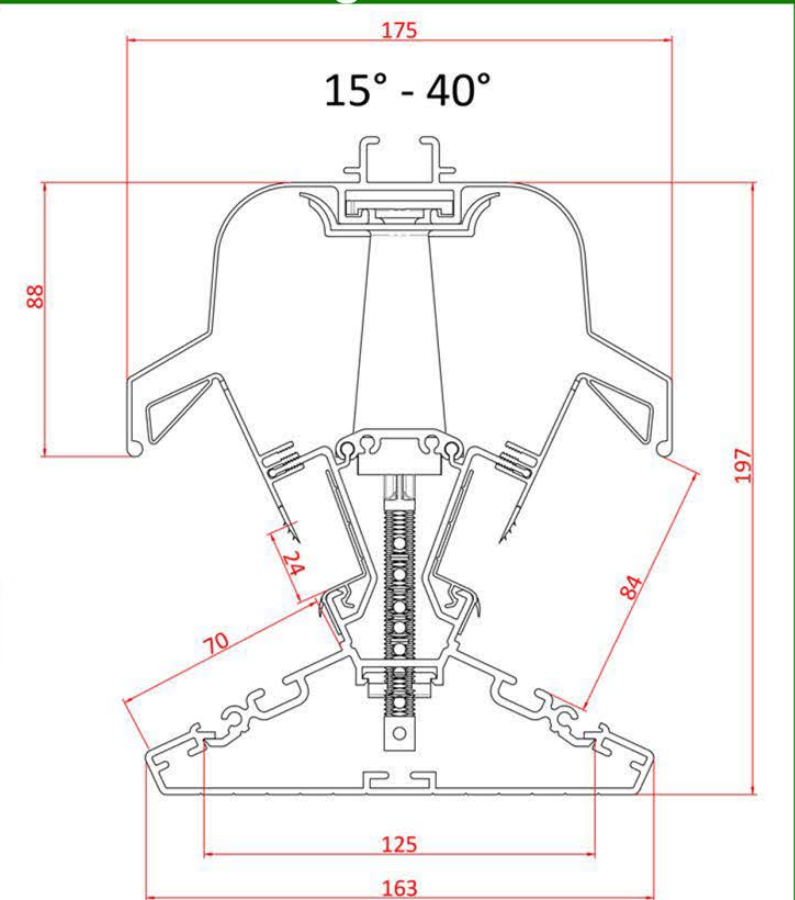
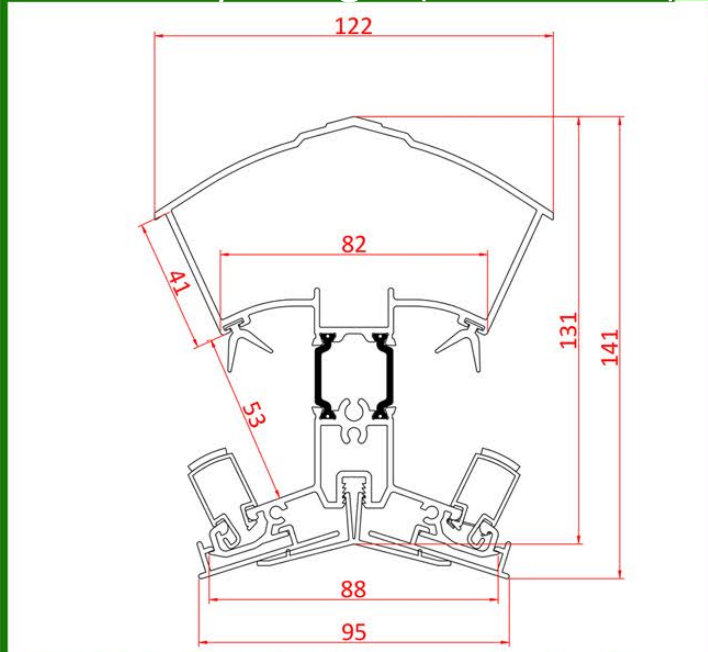

# PWLA Wallplate 5° - 45°

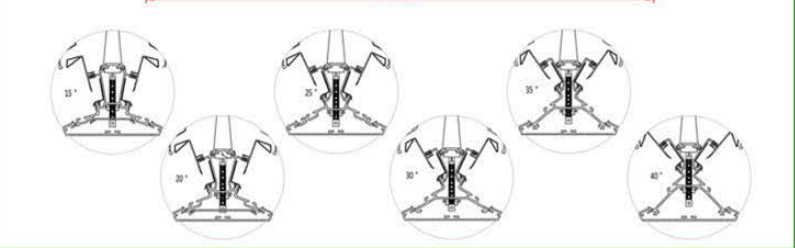
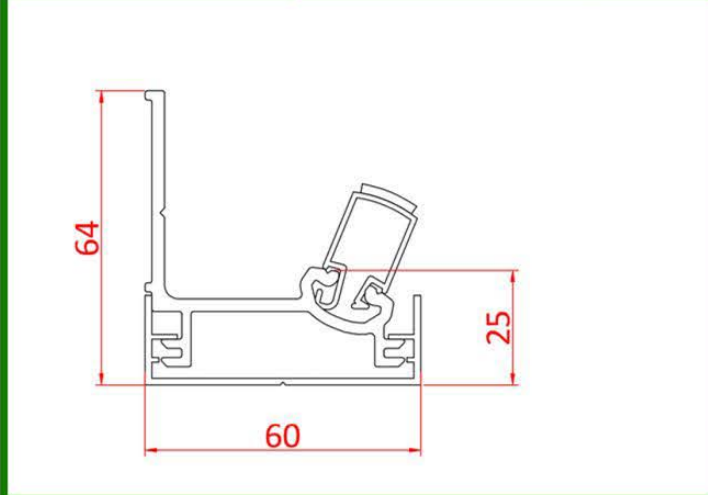

# MK5 Ful Ridge 15° - 40°

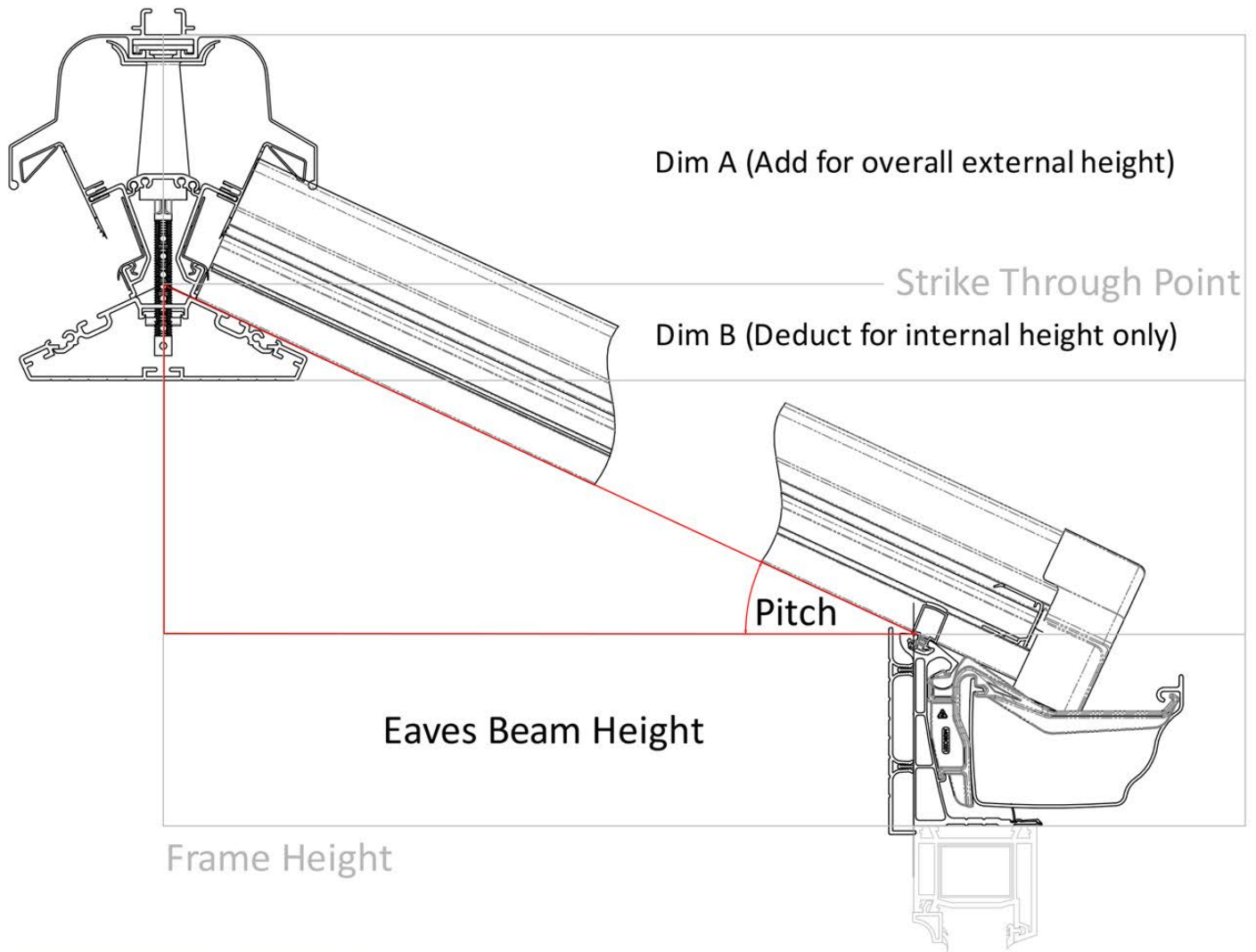

Ridge Body Height		E = Eaves Height	Dimension B
P = Pitch	Dim A		
15°	154	109	44
20°	148	109	48
25°	142	109	56
30°	136	110	61
35°	130	110	71
40°	124	110	81

$$\begin{aligned} & \text{HALF WIDTH} \\ & \quad \times \\ & \quad \text{TAN (PITCH)} \\ & \quad + \\ & \quad \text{EAVES HEIGHT} \\ & \quad = \\ & \text{STRIKE THROUGH POINT} \end{aligned}$$

Then either:

ADD DIM A for OVERALL HEIGHT

MINUS Dimension B  
for INTERNAL HEIGHT

# Ventilated Wallplate 5° - 30°

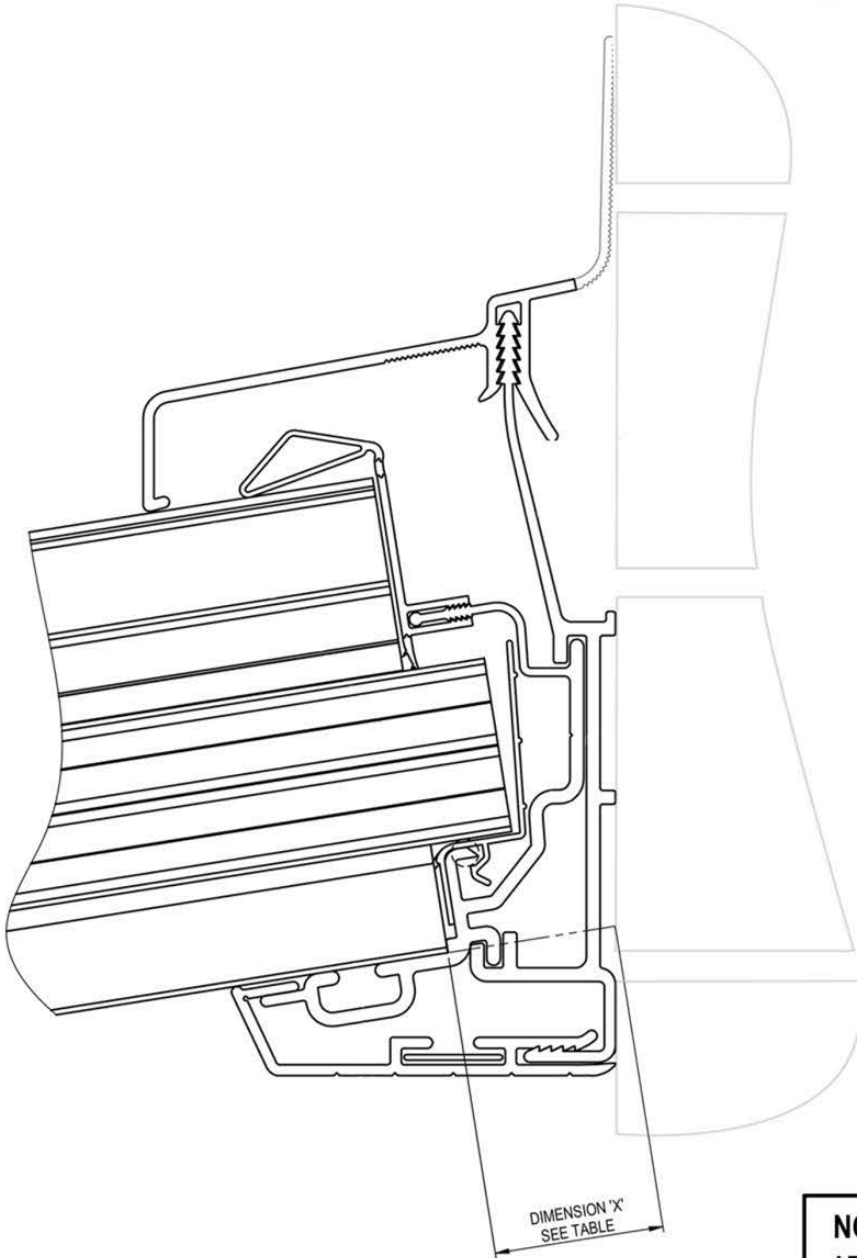

PITCH ANGLE	DIMENSION 'X'
* 5°	34.40mm
6°	33.25mm
7°	32.35mm
8°	31.30mm
9°	31.00mm
* 10°	31.00mm
11°	30.30mm
12°	29.30mm
13°	28.20mm
14°	28.00mm
* 15°	28.10mm
16°	32.5mm
17°	32.00mm
18°	30.80mm
19°	30.9mm
* 20°	31.40mm
21°	35.25mm
22°	34.85mm
23°	34.00mm
24°	34.00mm
* 25°	34.25mm
26°	38.40mm
27°	38.00mm
28°	37.15mm
29°	37.30mm
30°	37.60mm

HALF WIDTH x TAN (PITCH) + EAVES HEIGHT

=

STRIKE THROUGH POINT

Then either:

ADD DIM A for OVERALL HEIGHT,

MINUS DIMENSION B for INTERNAL HEIGHT

## NOTE :- (DIMENSION 'X')

AT THE PACKER CHANGEOVER POINTS

INDICATED IN THE TABLE THUS -\*

IF THE PITCH IS GREATER THAN THE VALUE

INDICATED USE THE NEXT PITCH UP.

EG. FOR 20.1° USE 21° VALUE FOR DIMENSION 'X'

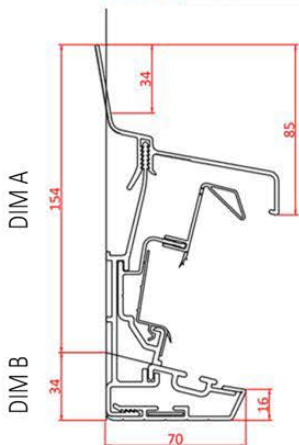

10.1° - 15° Pitch

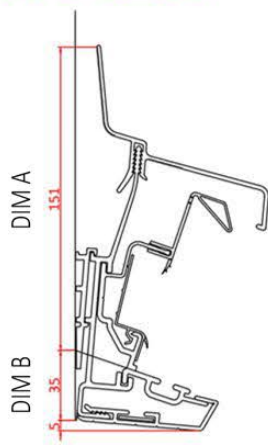

15.1° - 20° Pitch

(1 x 5° packer required)

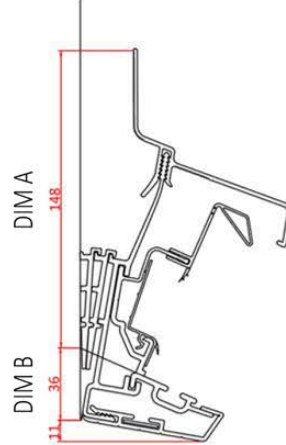

20.1° - 25° Pitch

(2 x 5° packer required)

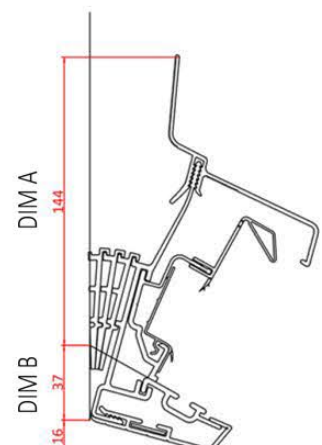

25.1° - 30° Pitch

(3 x 5° packer required)

# PWLA Walplate 5° - 45°

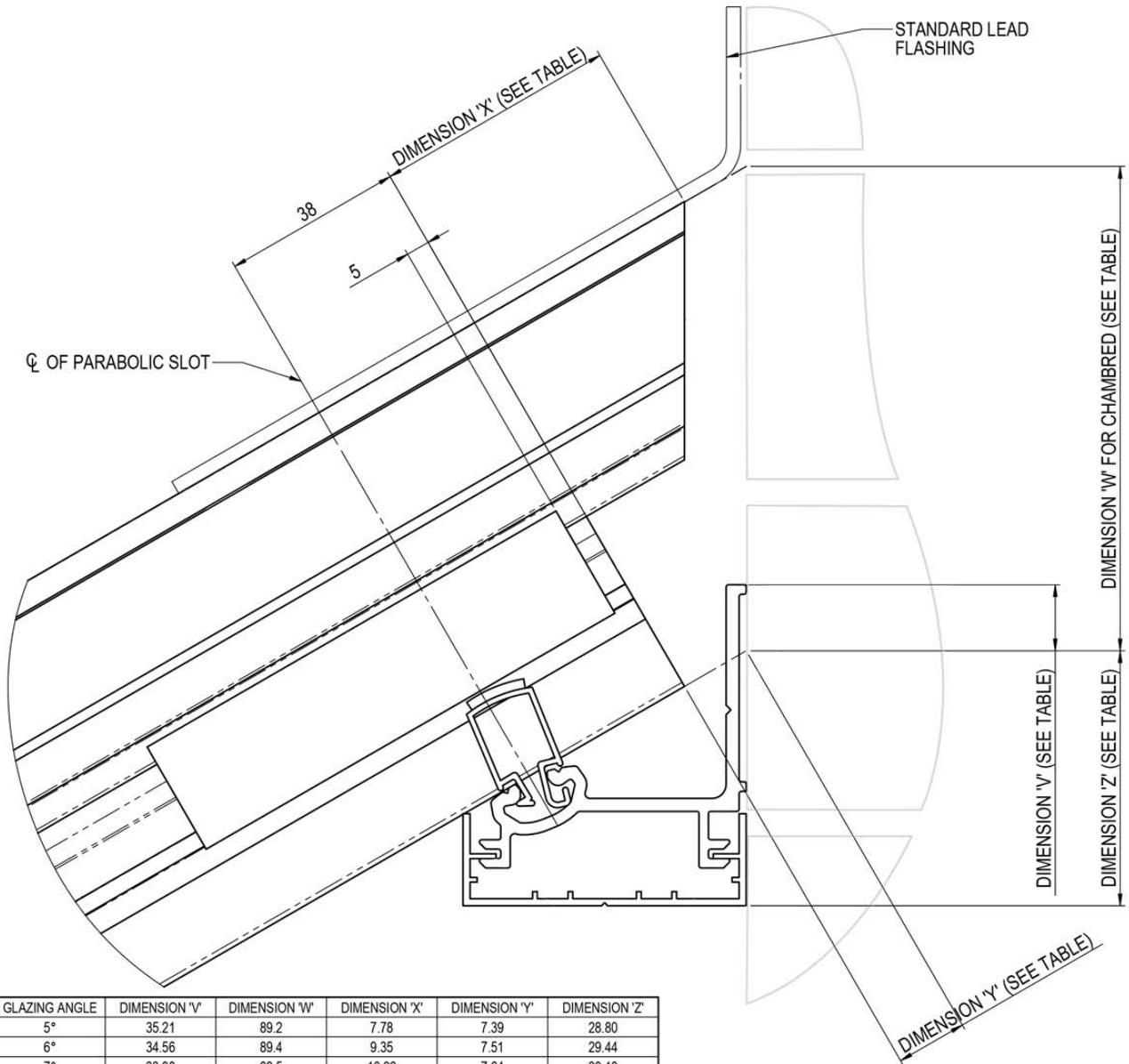

GLAZING ANGLE	DIMENSION 'V'	DIMENSION 'W'	DIMENSION 'X'	DIMENSION 'Y'	DIMENSION 'Z'
5°	35.21	89.2	7.78	7.39	28.80
6°	34.56	89.4	9.35	7.51	29.44
7°	33.90	89.5	10.92	7.64	30.10
8°	33.23	89.8	12.50	7.77	30.77
9°	32.54	90.00	14.09	7.92	31.46
10°	31.85	90.30	15.68	8.08	32.16
11°	31.13	90.50	17.29	8.26	32.87
12°	30.41	90.90	18.90	8.44	33.59
13°	29.67	90.12	20.53	8.64	34.39
14°	28.91	91.60	22.17	8.86	35.09
15°	28.14	92.0	23.83	9.09	35.87
16°	27.34	92.5	25.50	9.33	36.66
17°	26.54	92.90	27.19	9.60	41.46
18°	25.71	93.50	28.90	9.88	42.29
19°	24.86	94.00	30.64	10.18	43.14
20°	24.00	94.60	32.37	10.51	44.00
21°	23.11	95.20	34.14	10.85	44.89
22°	22.20	95.90	35.93	11.22	45.80
23°	21.26	96.60	37.75	11.60	46.74
24°	20.31	97.30	39.59	12.02	47.69
25°	19.32	98.10	41.47	12.46	48.68
26°	18.31	98.90	43.37	12.93	49.69
27°	17.28	99.80	45.31	13.42	50.72
28°	16.21	100.70	47.28	13.95	51.79
29°	15.11	101.6	49.29	14.51	52.89
30°	13.98	102.60	51.34	15.10	54.02
31°	12.82	103.70	53.43	15.70	55.18
32°	11.62	104.80	55.57	16.39	56.38
33°	10.38	106.00	57.75	17.10	57.62
34°	9.10	107.20	59.98	17.84	58.90
35°	7.78	108.50	62.27	18.63	60.22
36°	6.42	109.90	64.61	19.47	61.58
37°	5.01	111.30	67.01	20.36	62.99
38°	3.55	112.80	69.48	21.30	64.45
39°	2.04	114.40	72.01	22.29	65.96
40°	0.47	116.00	74.62	23.34	67.53
41°	-1.16	117.80	77.31	24.46	69.16
42°	-2.85	119.60	80.07	25.64	70.85
43°	-4.61	121.50	82.93	26.89	72.61
44°	-6.44	123.60	85.88	28.21	74.43
45°	-8.34	125.70	88.93	29.61	76.34

PROJECTION  
 $\times$   
 TAN (PITCH)  
 $+$   
 EAVES HEIGHT  
 $=$   
 STRIKE THROUGH POINT  
 Then either:  
 ADD DIM W for OVERALL HEIGHT  
 MINUS Dimension Z  
 for INTERNAL HEIGHT

# Bar only

# 25mm Glazing Only

# 35mm Glazing Only

# Aluminium

# Transom Glazing Bars

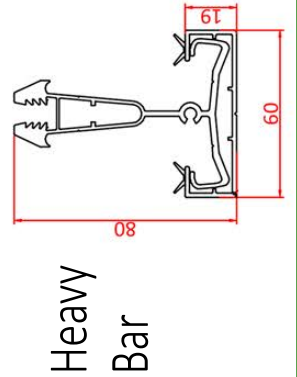
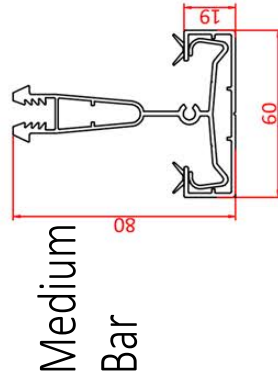
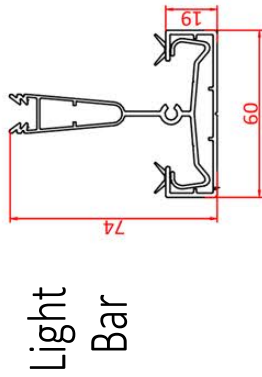

Dome PVC 25mm glazing only

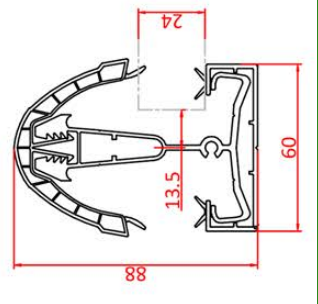
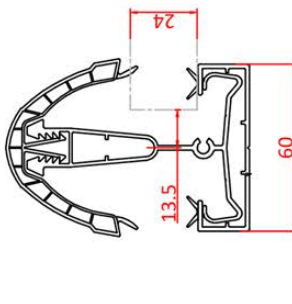
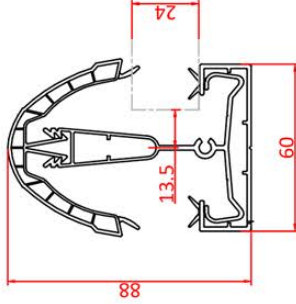

Dome PVC 35mm glazing only

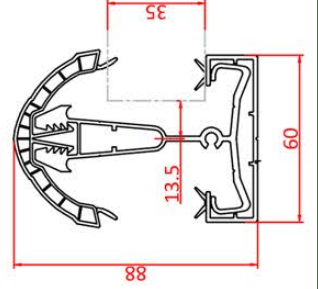
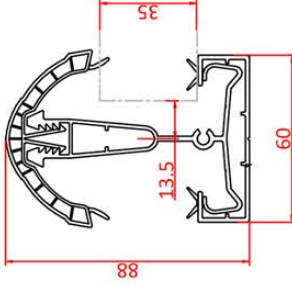
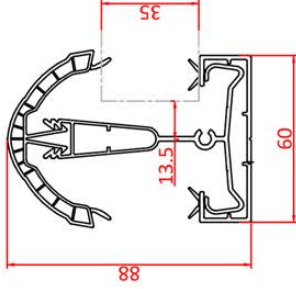

Dome PVC 35mm glazing only

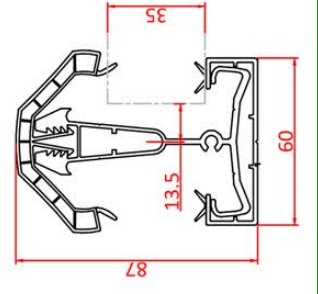
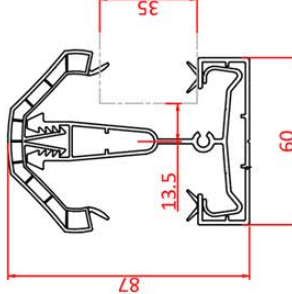
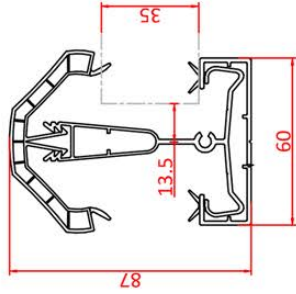

Bevel PVC 35mm glazing only

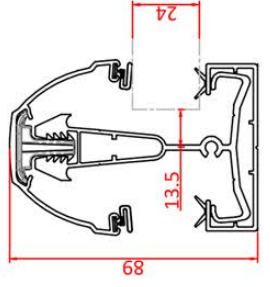
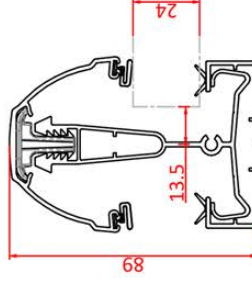
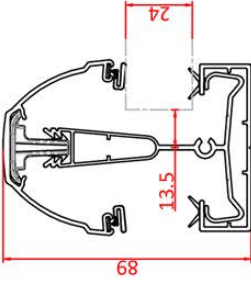

Aluminium 25mm glazing only

# Starter Bars 25/35mm

## Starter Bars - PVC 25 and 35mm

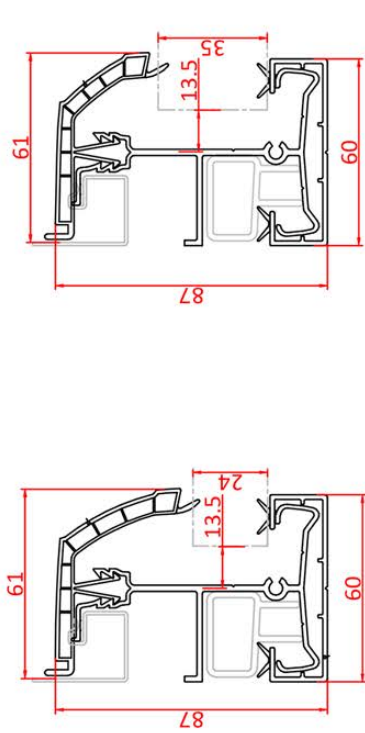

## Gable Bars - Aluminium 25mm only

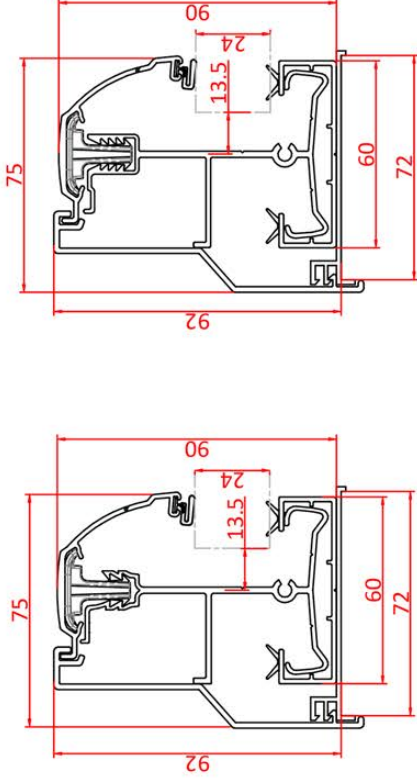

## Starter Bar - Ali

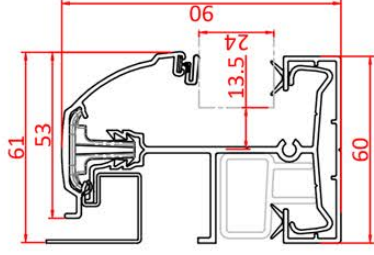

# 25mm Aluminium Options

## Gable Design Starter Bars 25/35mm

## Gable Bars - PVC - 25 and 35mm glazing

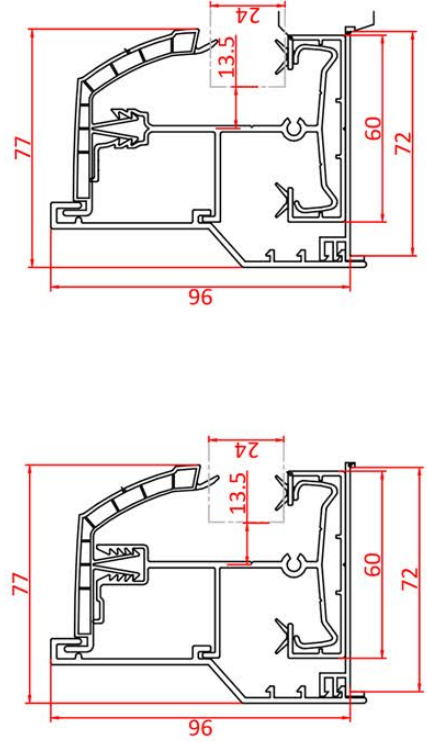

## Soaker Trim

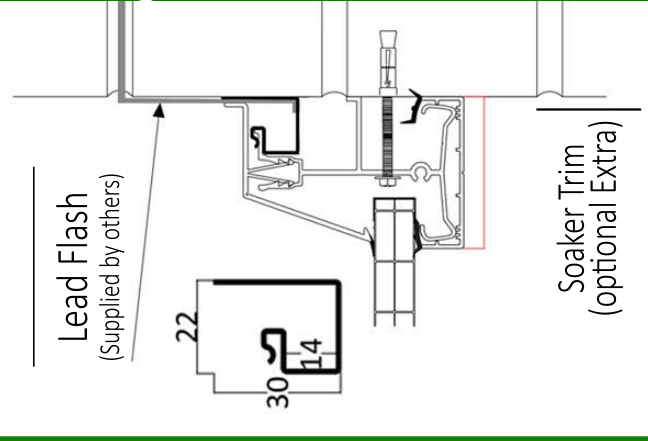
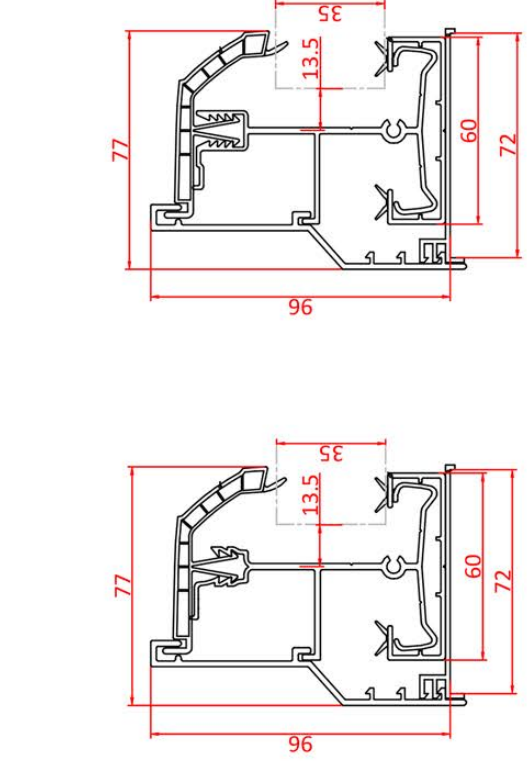



# Georgian Hip Bars 25/35mm

Georgian Hip Bars - PVC 25 and 35mm glazing

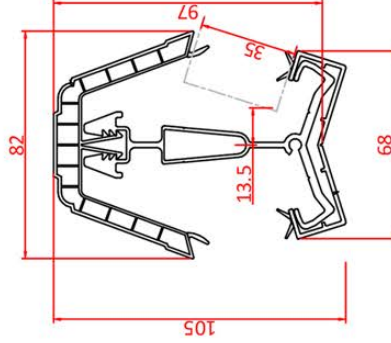
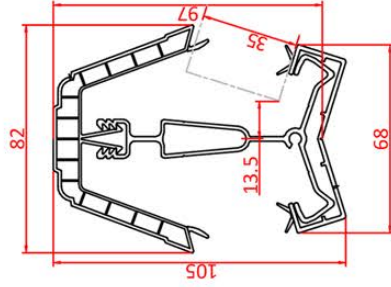
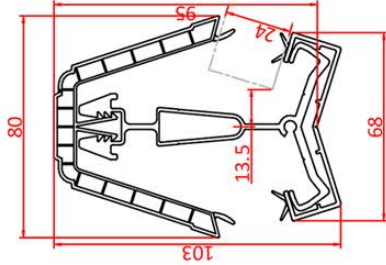
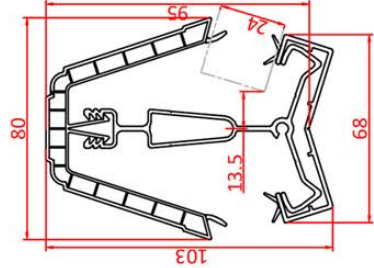

# 25mm Aluminium Options

Georgian Hip Bars - Aluminium 25mm only

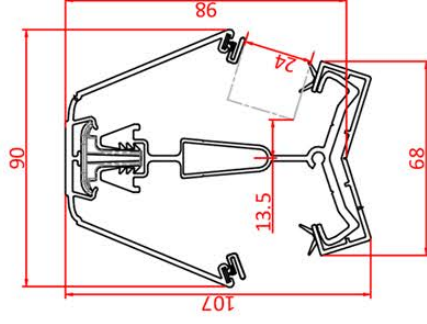
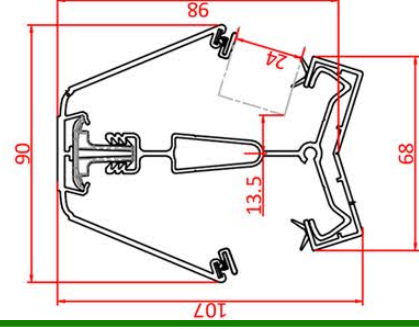

# Transom Bar/Victorian Hips - Super-Bolsters-

# Georgian Hip

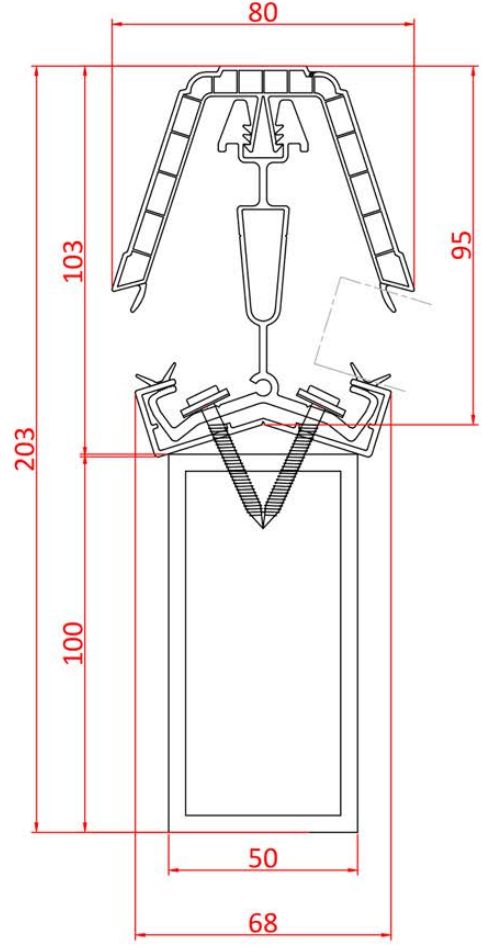
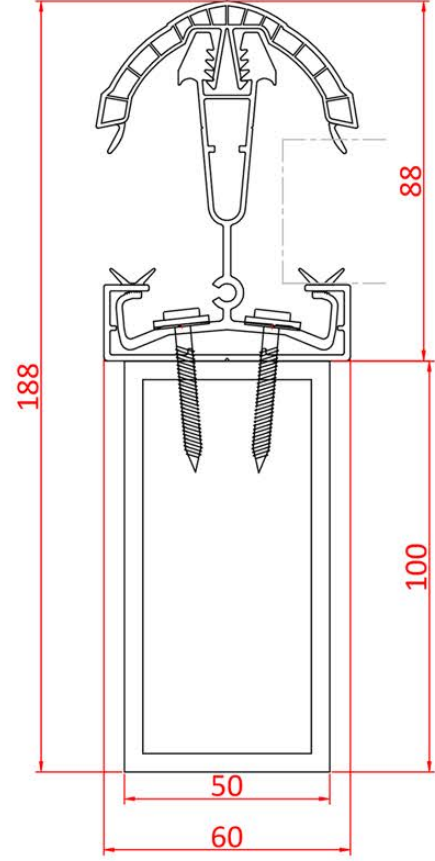

# Bolstered Glazing Bars

Aluminium Option

35mm Option

25mm Option

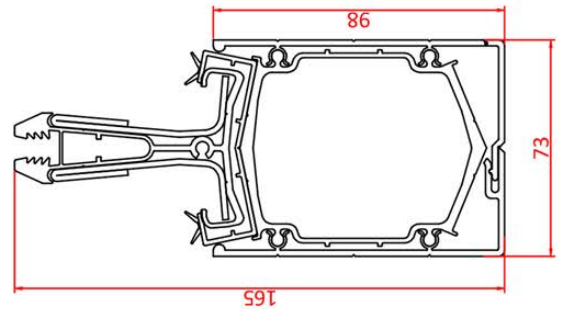
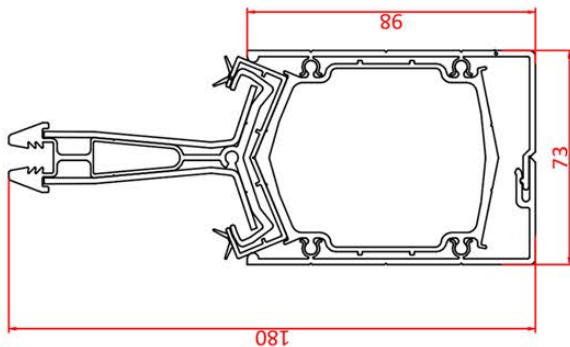
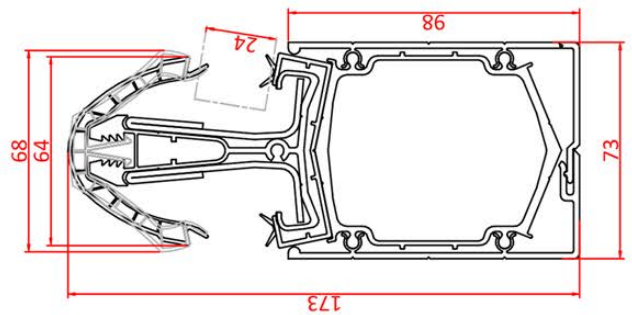
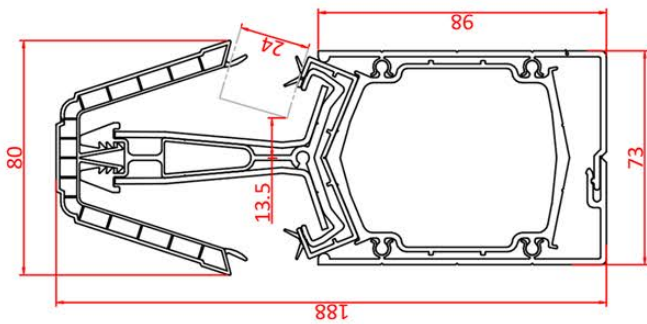
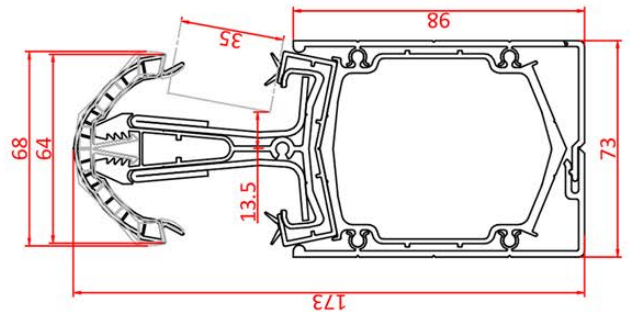
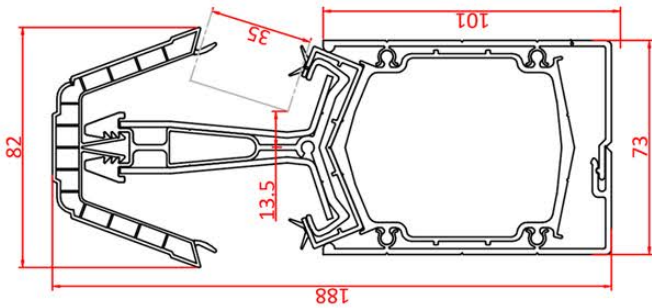
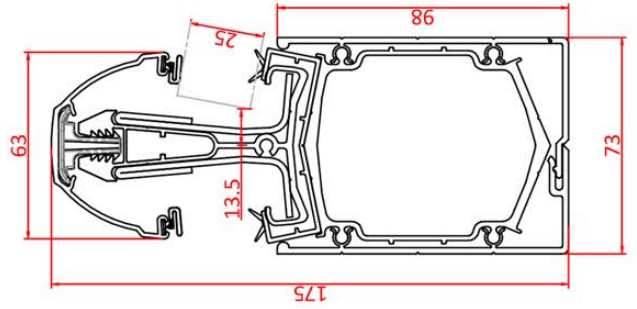
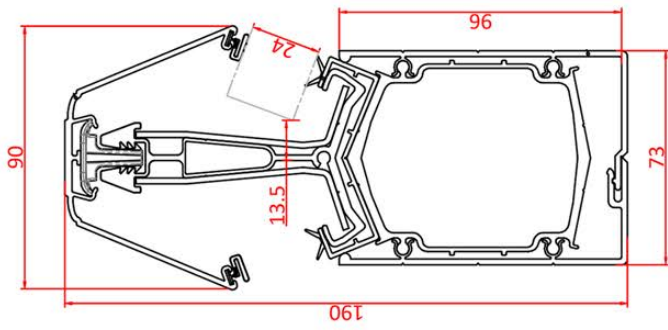

Georgian Hip Bar

Victorian Hip/Transom Bar

# Cornice

## Standard Eaves Beam

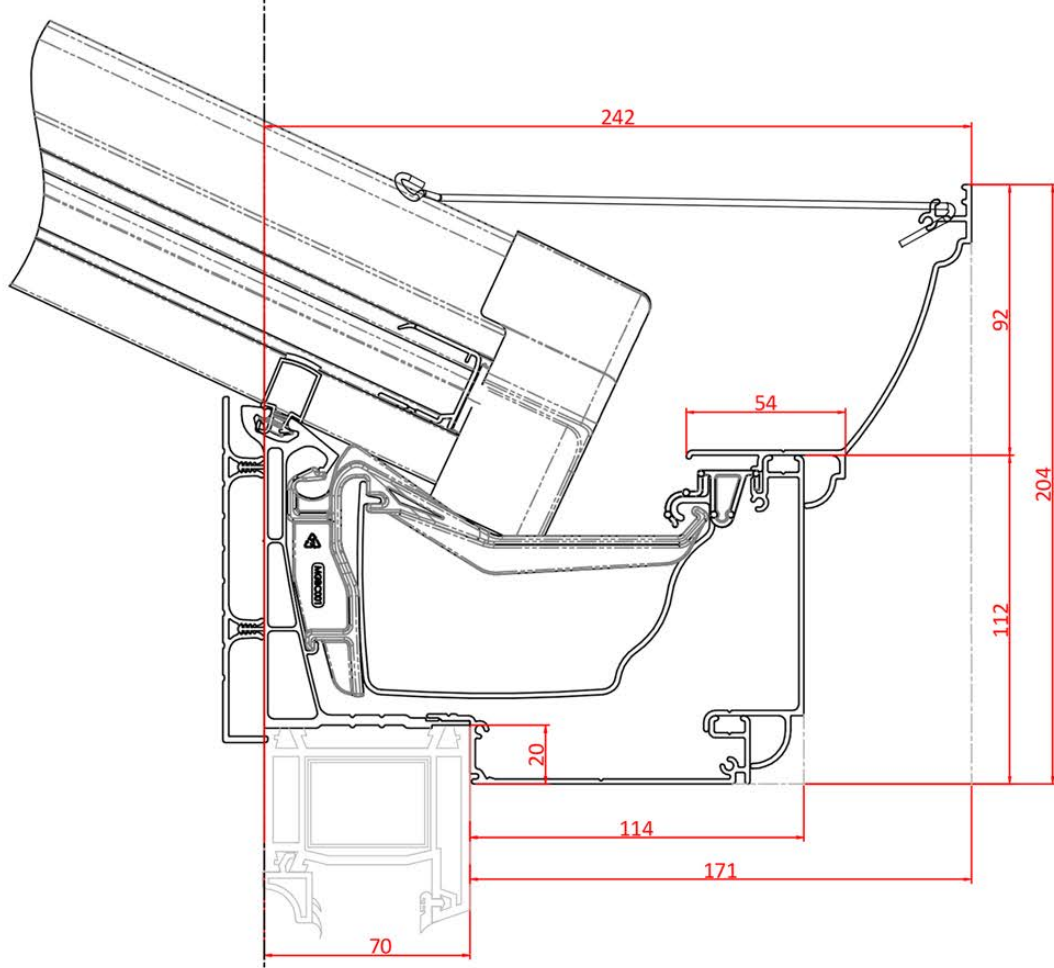

## Structural Eaves Beam

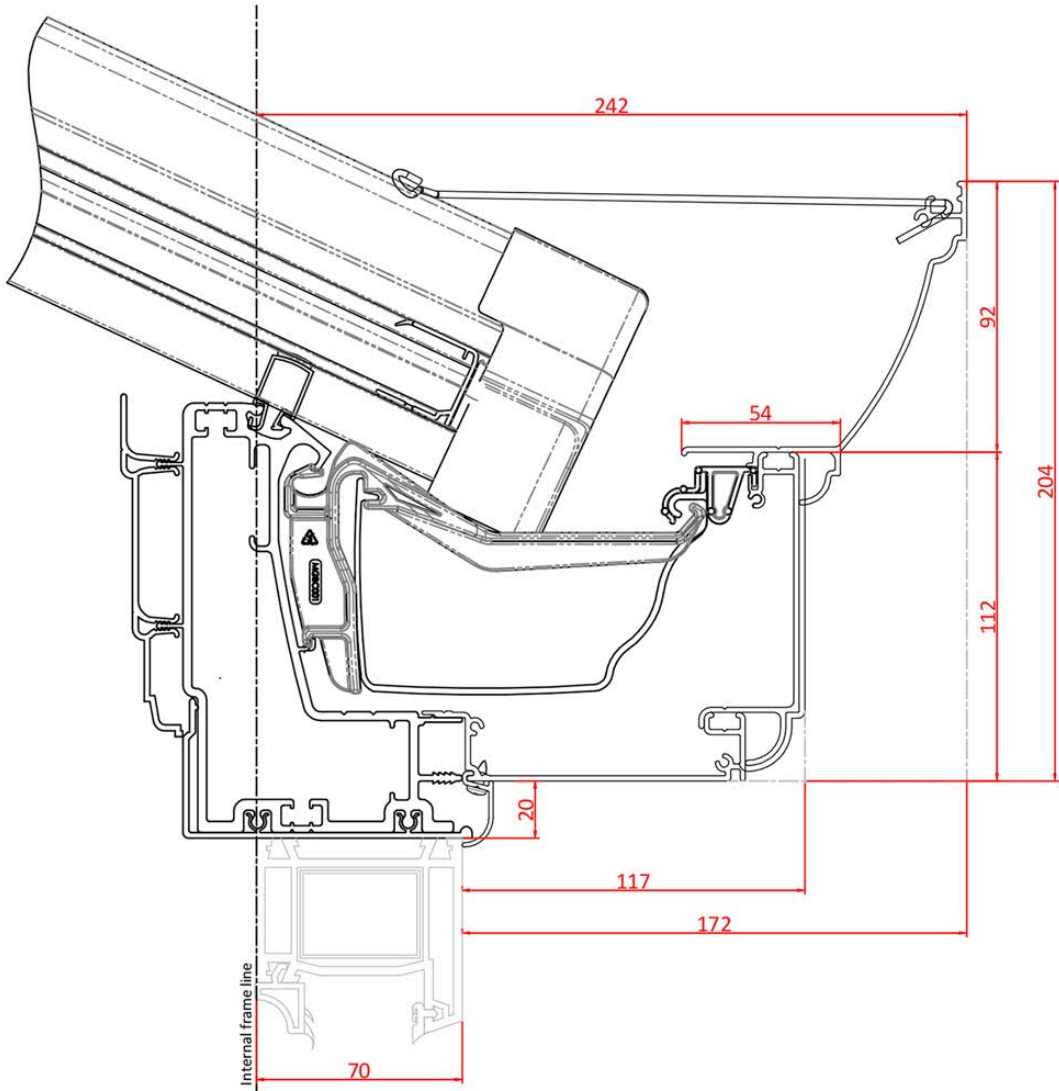

# Cornice

Two Tier Standard Eaves Beam

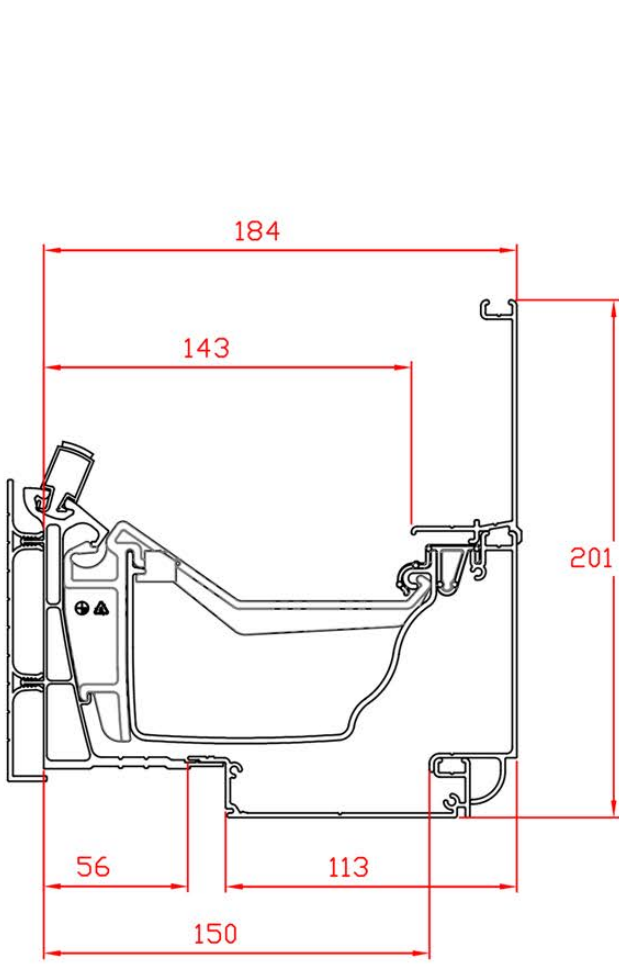

Three Tier Structural Eaves Beam

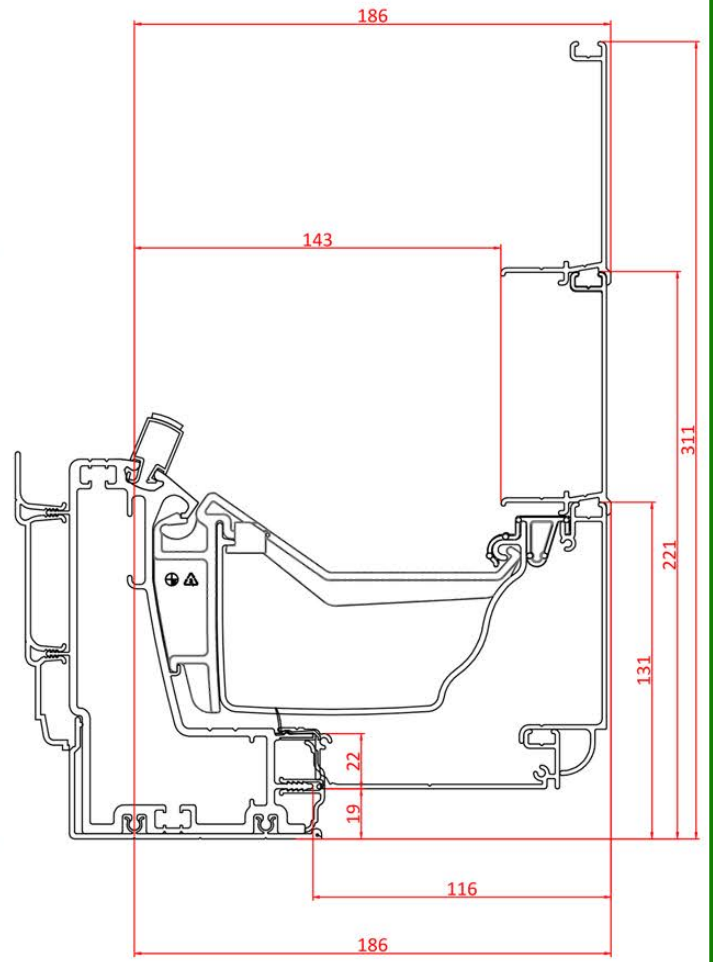
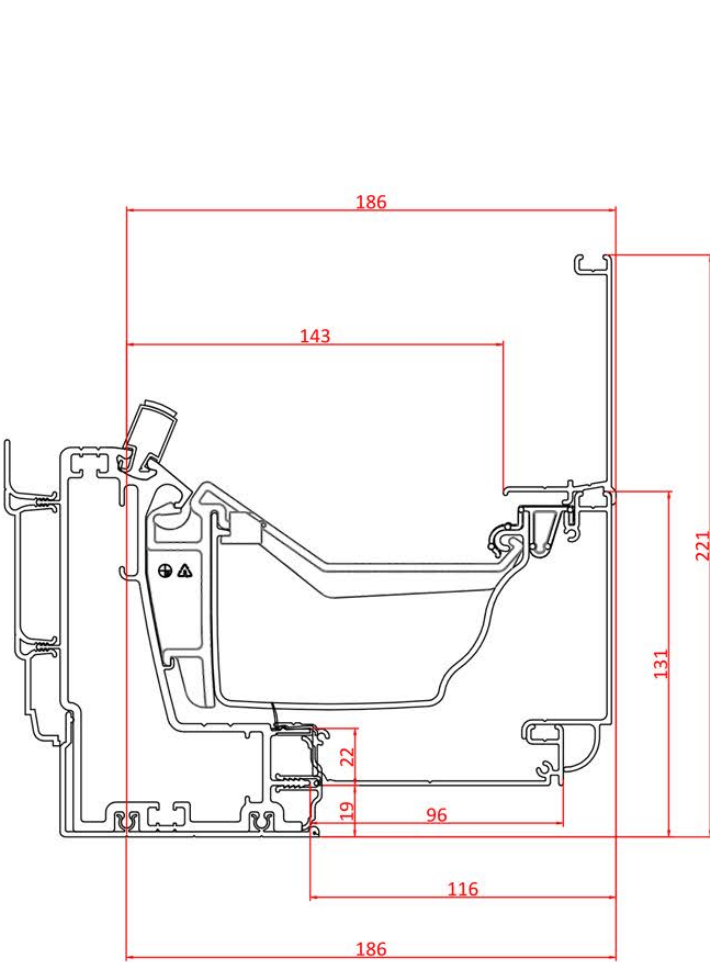

# Abutment

# Inline

# 90° Corner

# Small

# Loggia

# Large

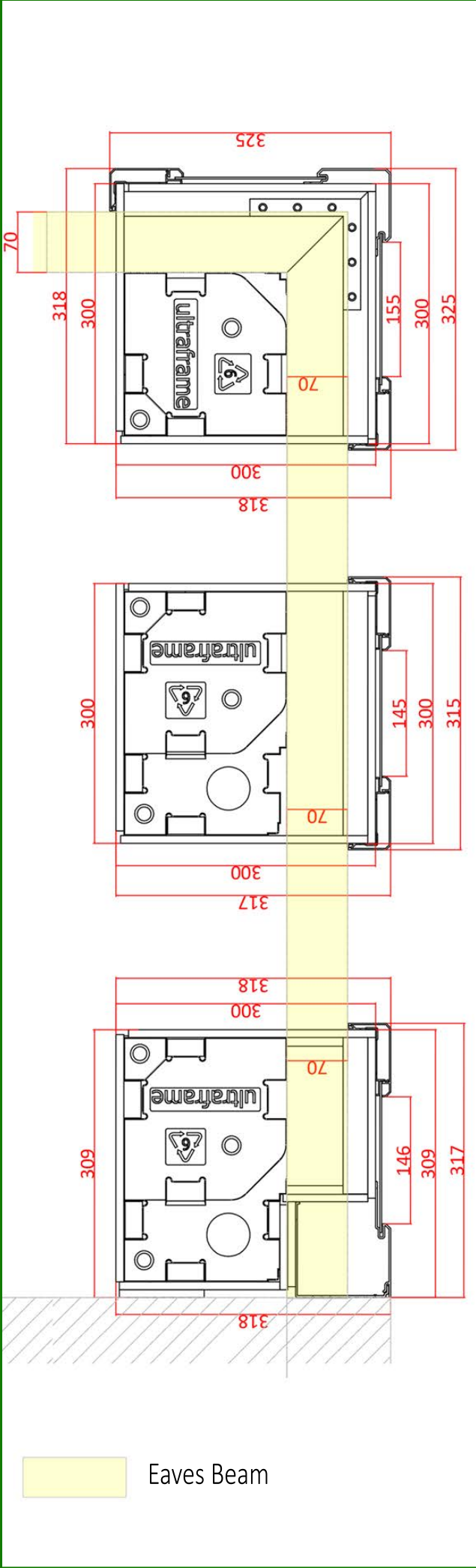

# 90° Corner

# Inline

# Abutment

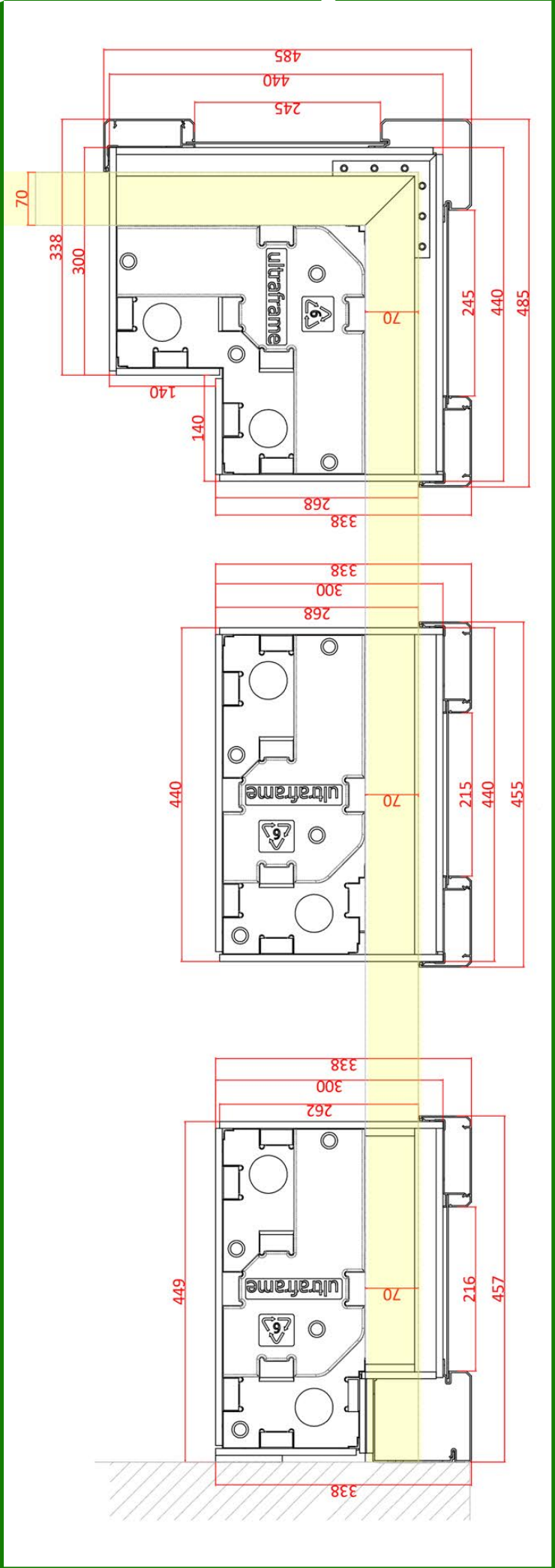

# Finials and Crestings

## FINIALS & CRESTINGS MEASUREMENTS

Elizabethan

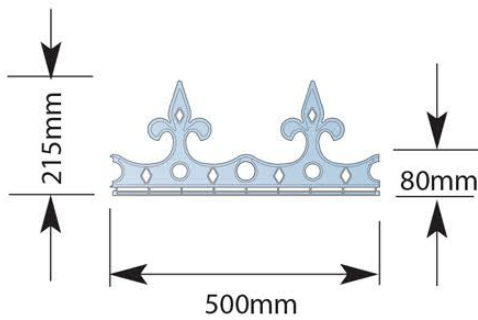

Renaissance

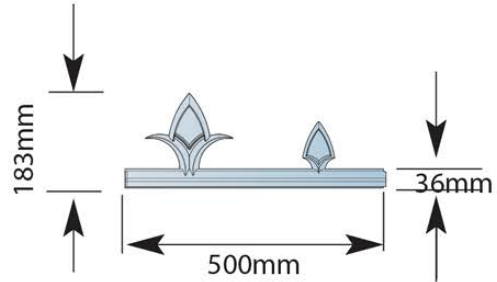

Classic

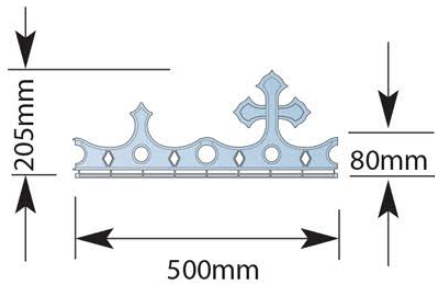

Baroque

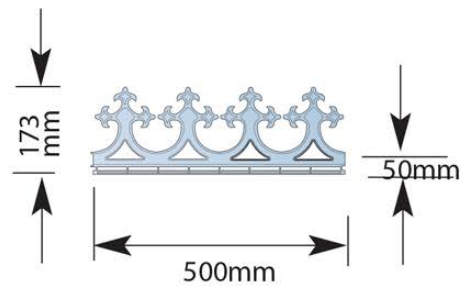

Tudor

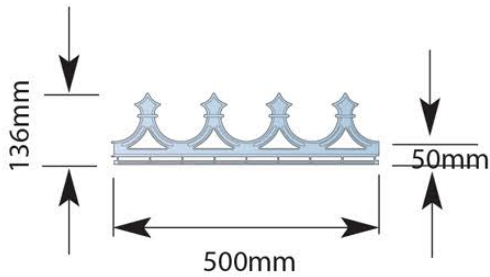

## Dentil Mouldings

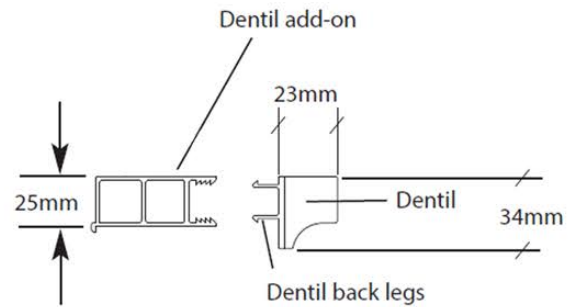

Ball

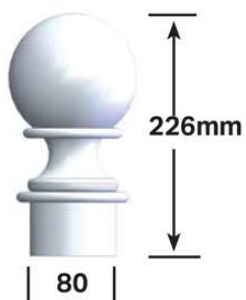

Coronet

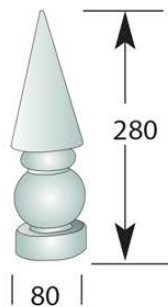

Pikestaff

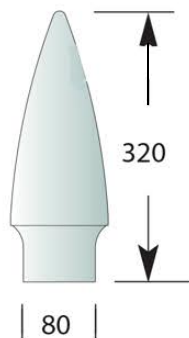

Sceptre

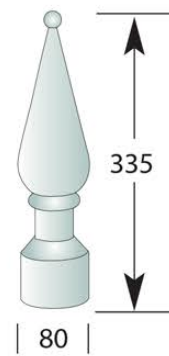

Classic

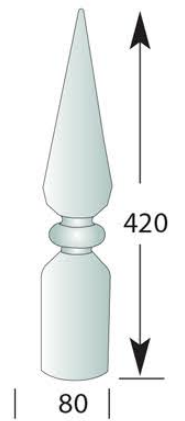



[www.ultraframetrade.co.uk](http://www.ultraframetrade.co.uk)

Ultraframe<sup>®</sup>

It is Ultraframe's policy to continually seek to improve its products, processes and services, and we reserve the right to change specifications without prior notice. Ultraframe is a trading name of Ultraframe (UK) Limited.

